

NOTICE DE POSE

Espace d'angle Konsilio

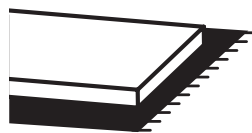

PRÉPARATION



- Veillez à ce que le **sol** de l'emplacement soit de niveau.
- L'espace de montage doit être **propre** et **dégagé**, prévoir **3m x 3m** au sol.

OUTILS

NON FOURNIS :



Maillet

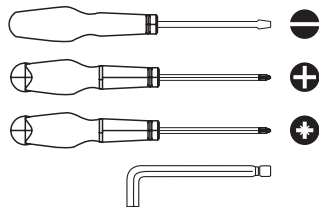

Tournevis et clé 6 pans



Visseuse



Perceuse

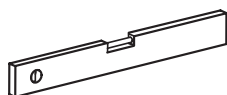

Niveau à bulle



Crayon



Eau savonneuse + chiffon

QUINCAILLERIE : composition des sachets



LES CHEVILLES ET VIS DE FIXATION AU MUR NE SONT PAS FOURNIS

Sachet pour joue n°825

A	équerre	x1
B	cache	x1
C	tourillon	x2
D	insert métallique	x4
E	goujon fil métal	x4
F	vis	x2

Sachet pour joue d'angle n°849

D	insert métallique	x8
E	goujon fil métal	x8
C	tourillon	x6

Sachet pour plinthe n°801

G	clip de plinthe	x2
H	support clip de plinthe	x2
F	vis	x4

Sachet pour tasseau n°832

S	vis	x6
---	-----	----

Sachet pour tasseau d'angle n°846

D	insert métallique	x3
E	goujon fil métal	x3
K	excentrique*	x3
S	vis	x3

Sachet pour piétement tablette basse n°826

I	embase	x4
J	piéd	x4
F	vis	x16

Sachet pour tablette fixe n°827

K	excentrique*	x4
---	--------------	----

Sachet pour tablette semi-fixe n°804

L	boîtier	x4
M	goujon	x4

Sachet pour tablette semi-fixe d'angle n°847

T	goujon double	x2
C	tourillon	x2
L	boîtier	x2
M	goujon	x2

Sachet pour tablette fixe d'angle n°848

T	goujon double	x2
---	---------------	----

Sachet pour tringle n°828

P	support tringle	x2
F	vis	x2

Sachet pour tringle d'angle n°850

U	coude de jonction	x1
V	support sous tablette	x1
F	vis	x2

Sachet pour montant central n°834

Q	ferrure femelle	x5
R	ferrure mâle	x5
F	vis	x20

* Un sachet de caches excentrique est également fourni. Utilisez le pour masquer les excentriques (repère K page suivante) à la fin du montage

N° de sachet	825	849	801	832	846	826	827	804	847	848	828	850	834
Quantité	2	1	2	1	4	2	9	2	1	4	2	1	2

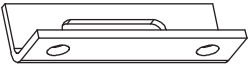
A  x2

B  x2

C  x12

D  x40

E  x28

F  x94

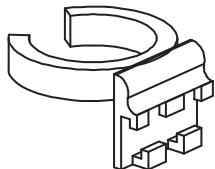
G  x4

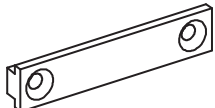
H  x4

K  x48

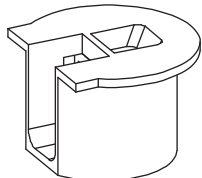
L  x10

M  x10

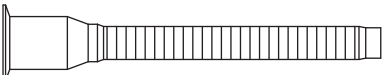
S  x18

P  x4

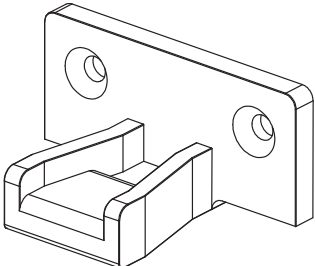
Q  x10

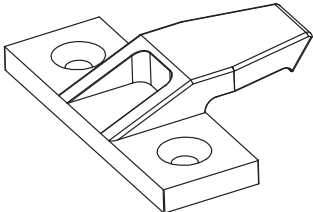
R  x10

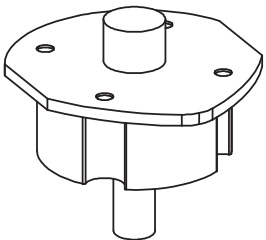
I  x8

T  x10
 ▲ Retirer les circlips sur les goujons double avant utilisation.

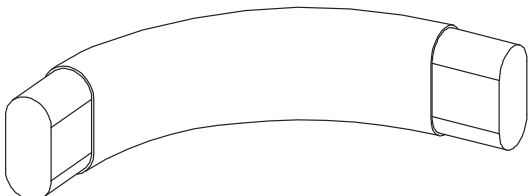
U  x1

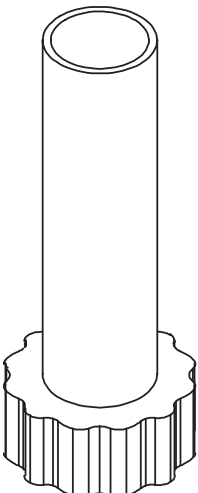
J  x8

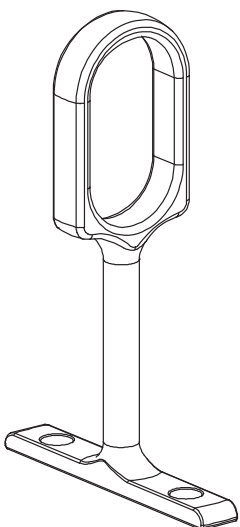
V  x1

NUMÉROTATION DES PIÈCES : repères

2 et 16 : largeur 100 mm

21 et 22 : largeur 122 mm

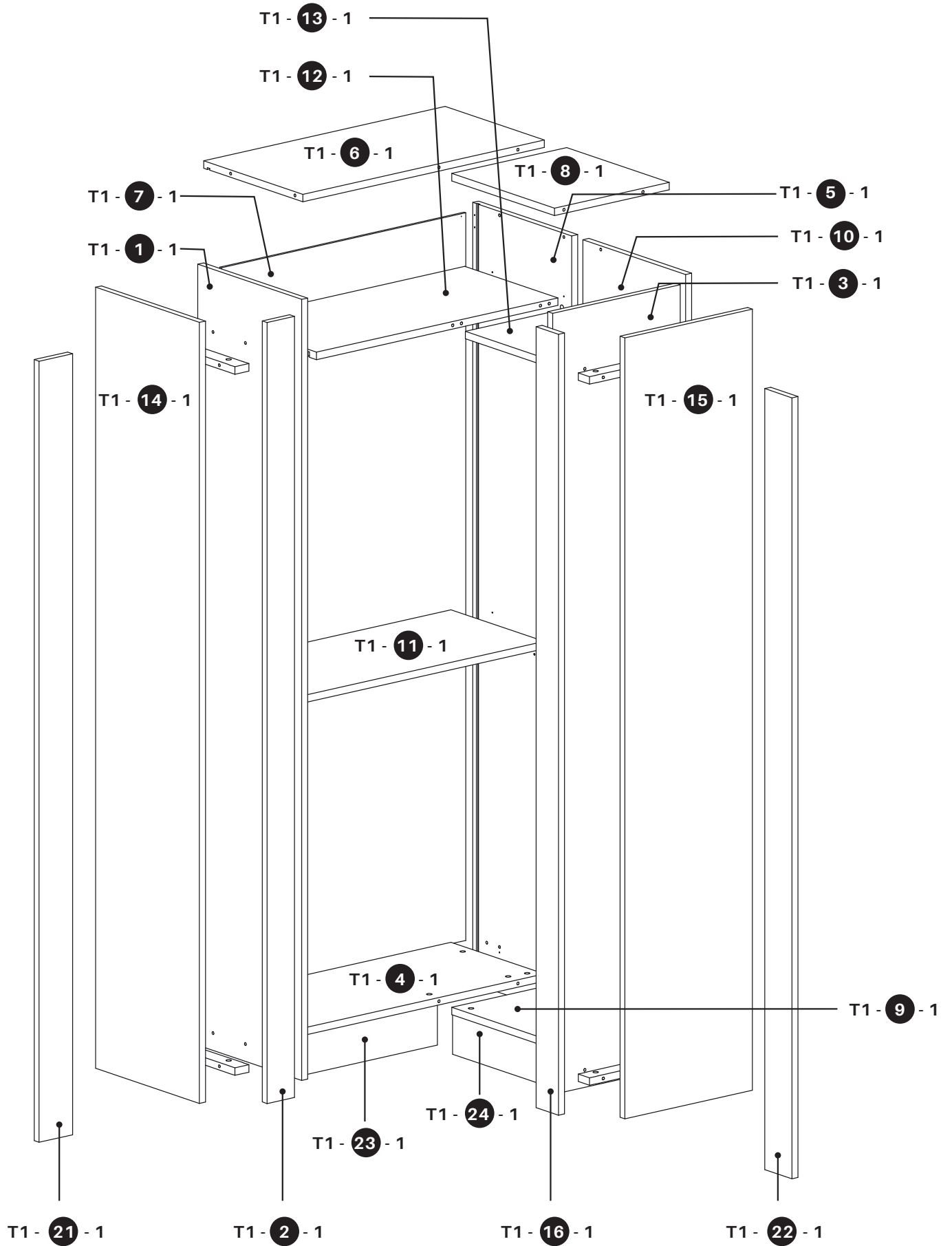

NUMÉROTATION DES PIÈCES

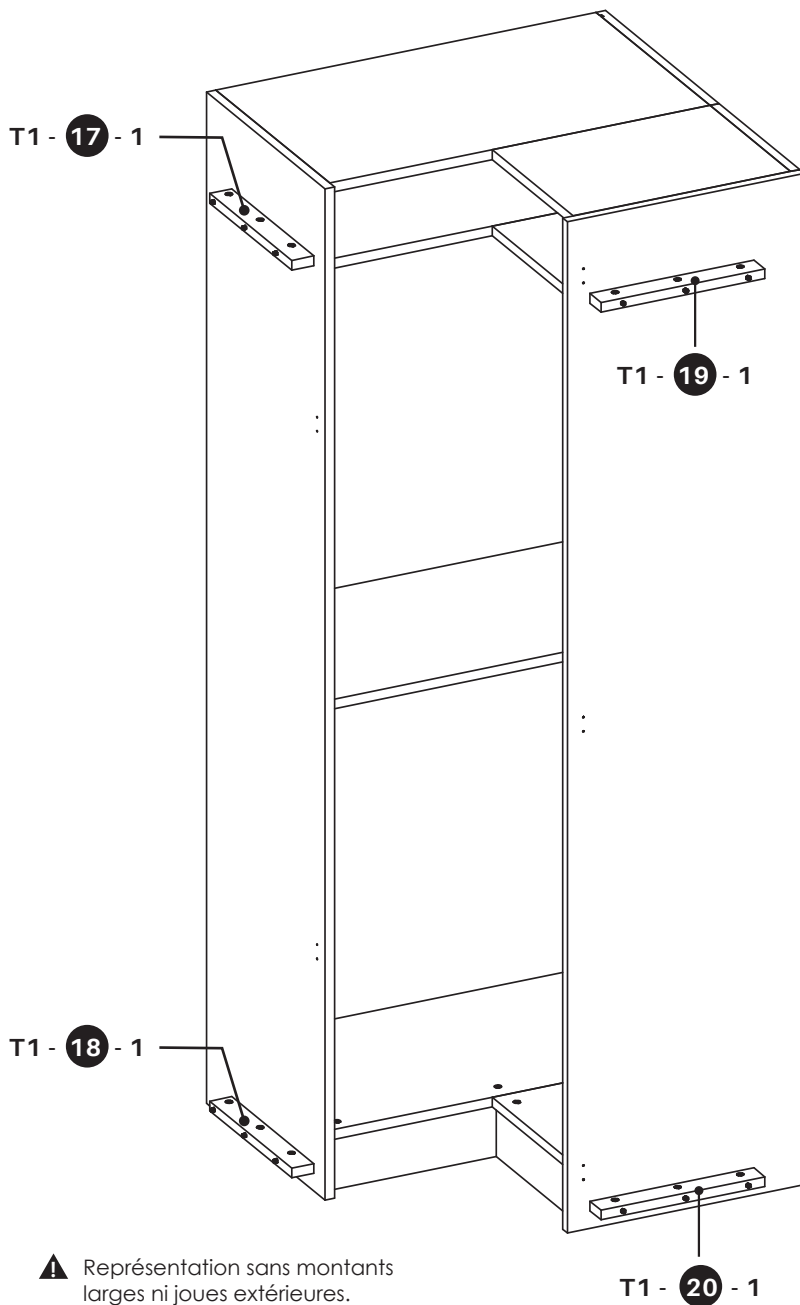

IDENTIFICATION DES PIÈCES

CCOK244603	AM006235
CPHL	
MME DUPONT	810891
SP4018164	J01 1 18/07/2022



Repère
T1-1-1
 N° Module

T1 - **1** - 1

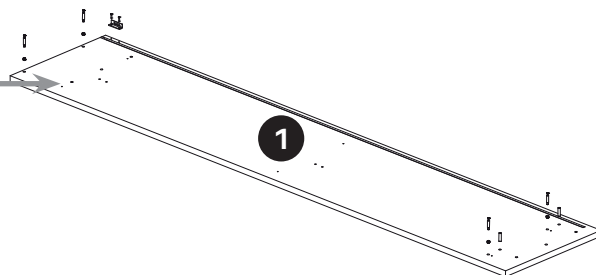

2445 x 465 x 22	OF10039732
Collection rangement Konsilio 1 espace d'angle	
Blanc Mat Colis 2 Joue Gauche	

ÉTIQUETTE PRODUIT

NUMÉROTATION NOTICE

1.

OUTILS	
tournevis	+
maillet	

QUINCAILLERIE		
Sacet n°825		
A	équerre	x1
C	tourillon	x2
D	insert métallique	x4
E	goujon fil métal	x4
F	vis	x2

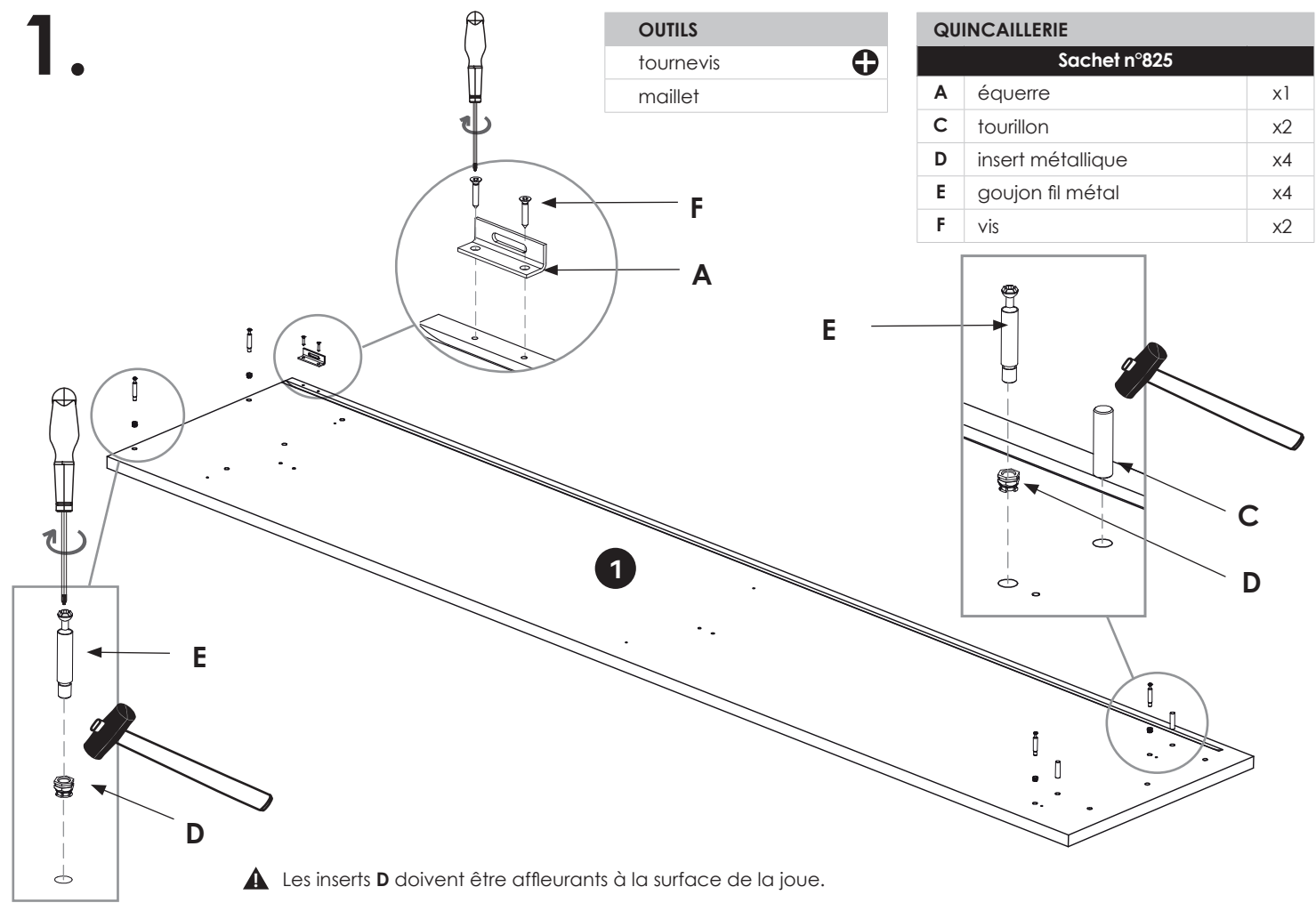

2.

OUTILS	
tournevis	+

QUINCAILLERIE		
Sacet n°826		
I	embase	x4
F	vis	x16

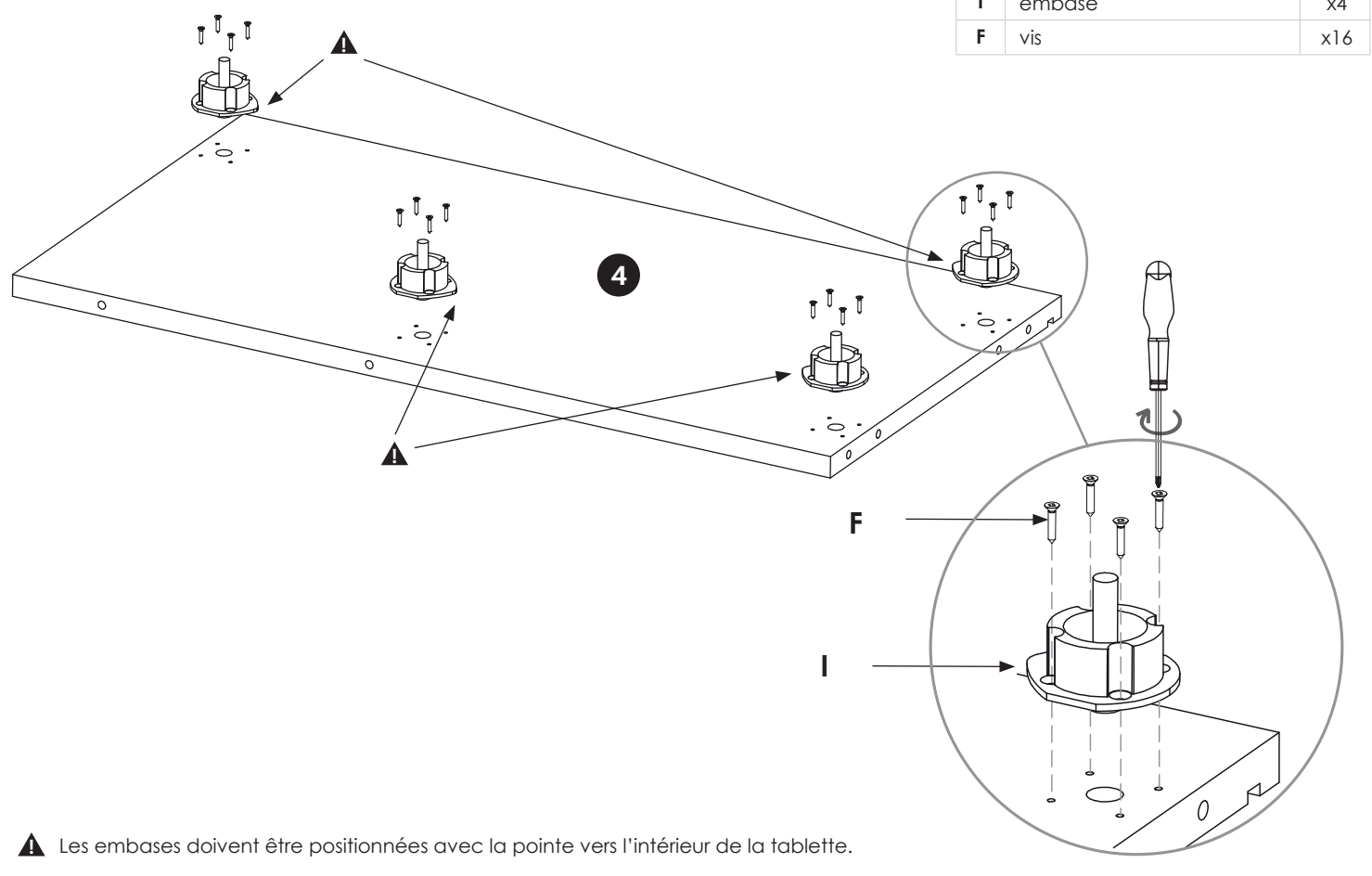

3.

QUINCAILLERIE

Sachet n°826

J pied

x4

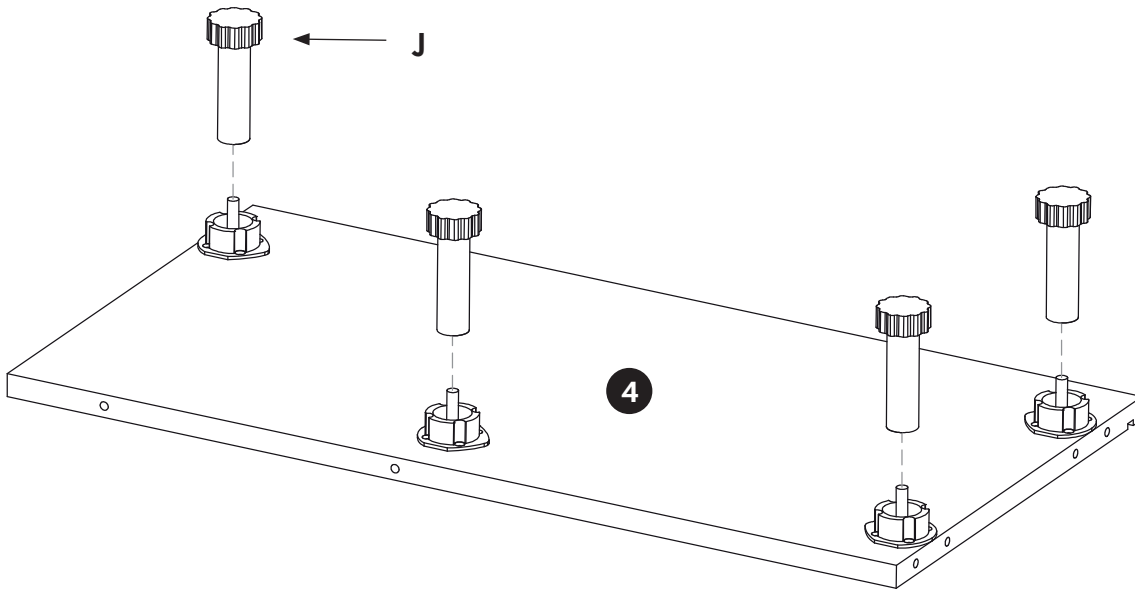

4.

Ajuster la longueur des pieds de réglage pour que la tablette 4 se trouve à 123 mm du sol, cette position pouvant varier selon la planéité du sol.

QUINCAILLERIE

Sachet n°827

x1½

K excentrique

x6

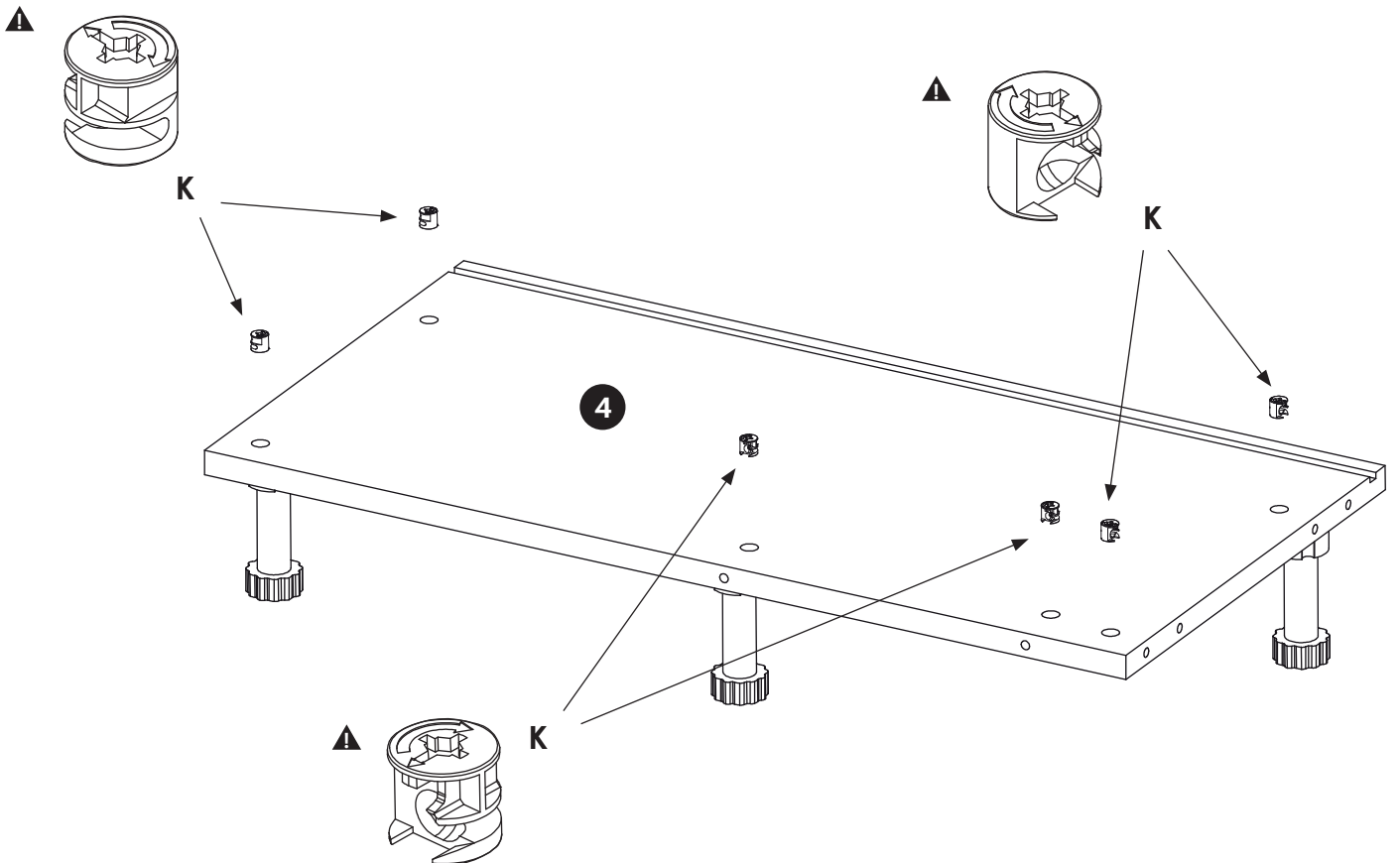

⚠ La flèche des excentriques est orientée vers l'extérieur de la tablette.

5.

QUINCAILLERIE

	Sachet n°827	x1½
K	excentrique	x6

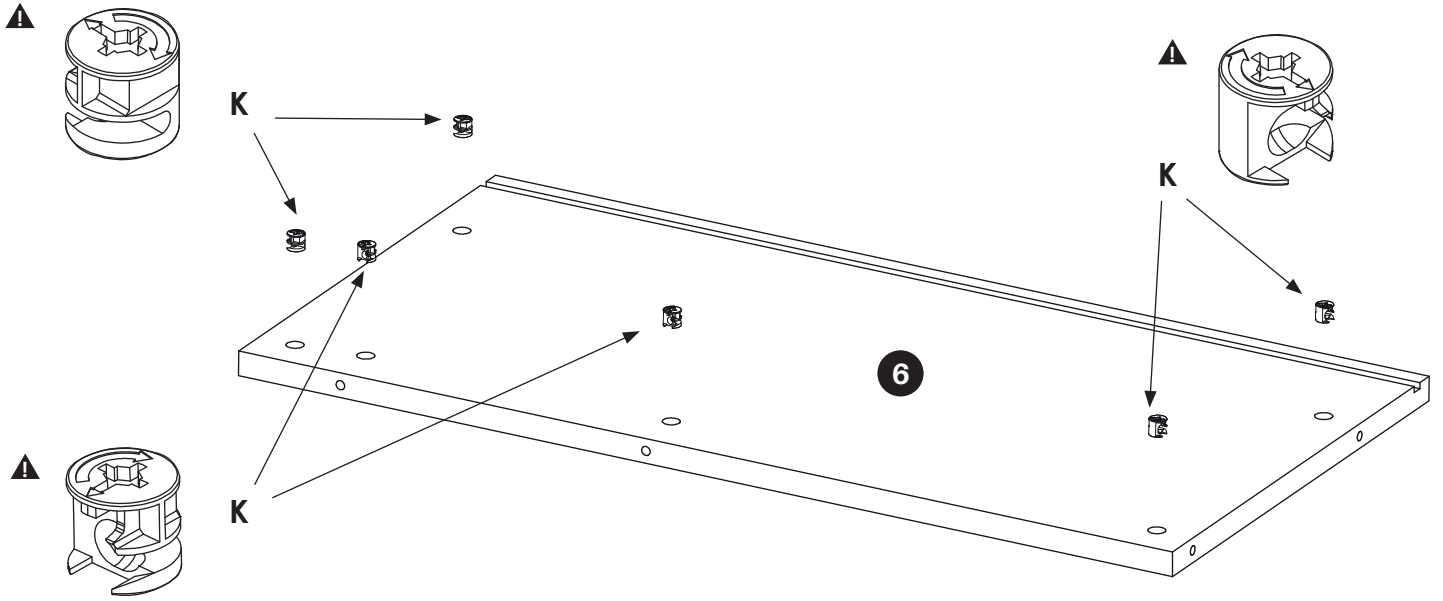

⚠ La flèche des excentriques est orientée vers l'extérieur de la tablette.

6.

OUTILS

tournevis

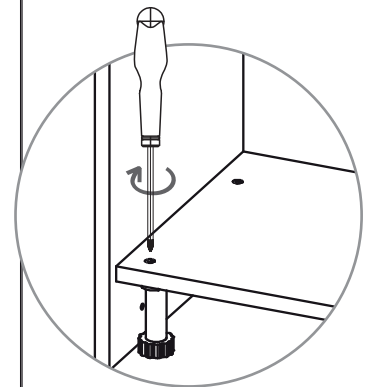
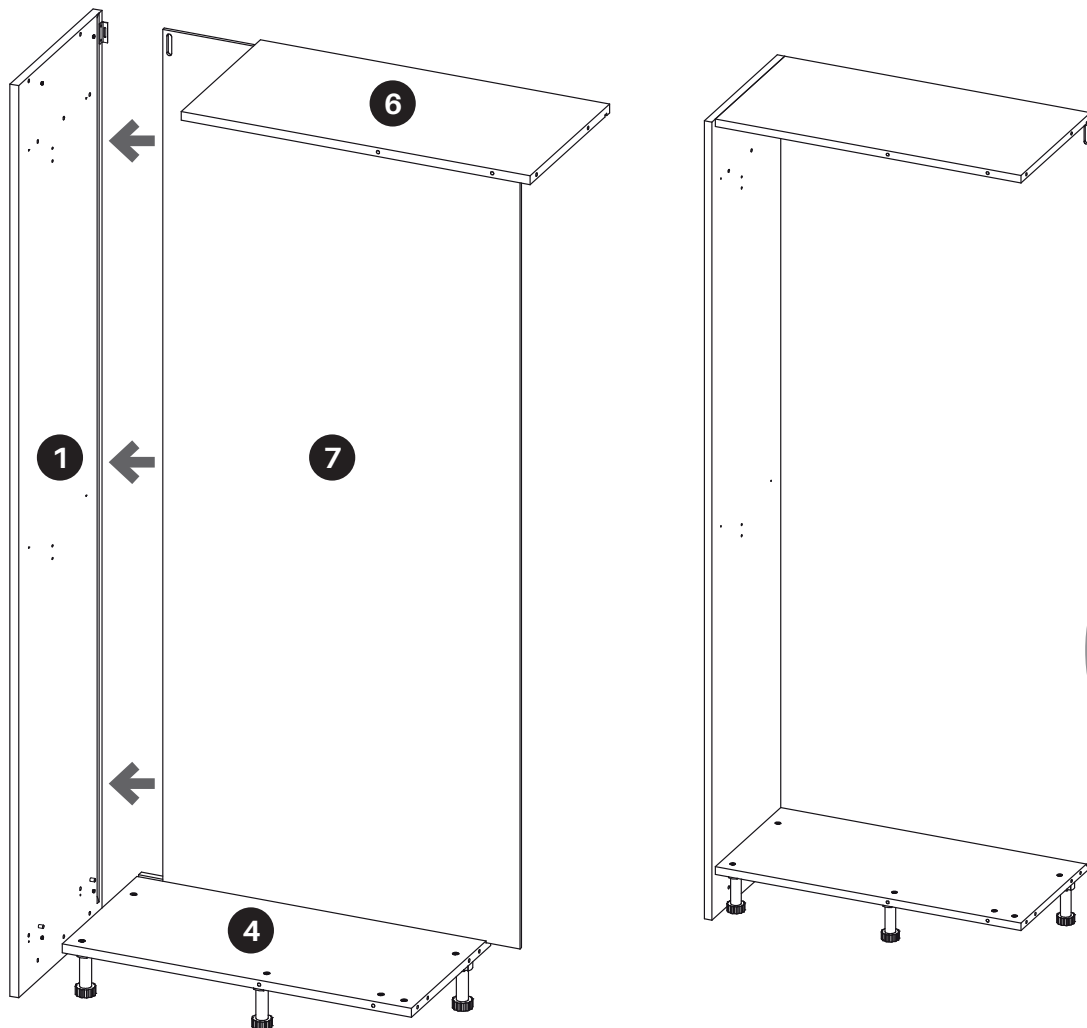

⚠ Serrer les excentriques dans le sens horaire

7.

OUTILS

tournevis 

maillet

QUINCAILLERIE

Sachet n°825

A équerre x1

C tourillon x2

D insert métallique x4

E goujon fil métal x4

F vis x2

Sachet n°827

K excentrique x4

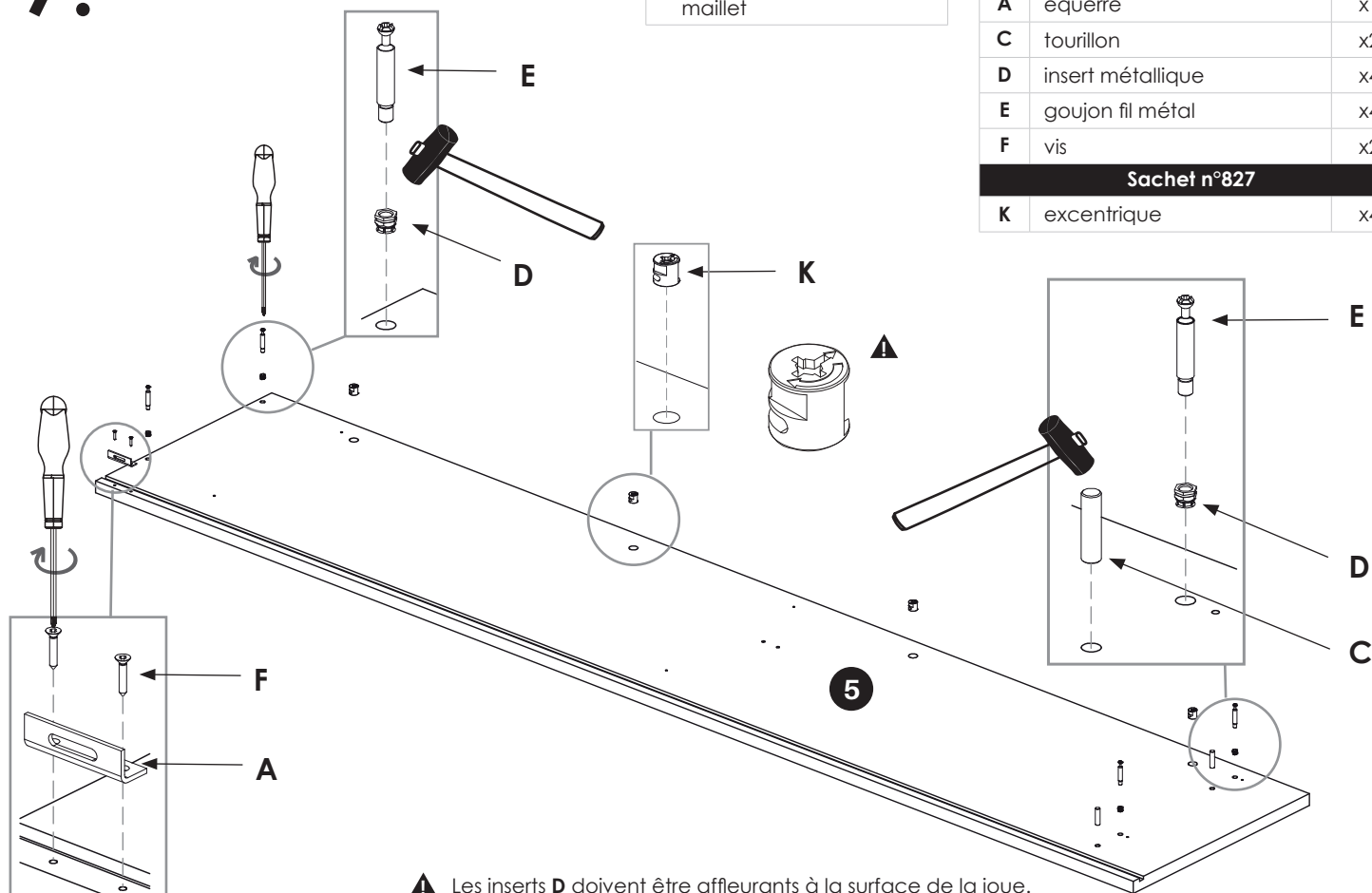



 Les inserts **D** doivent être affleurants à la surface de la joue.

8.

OUTILS

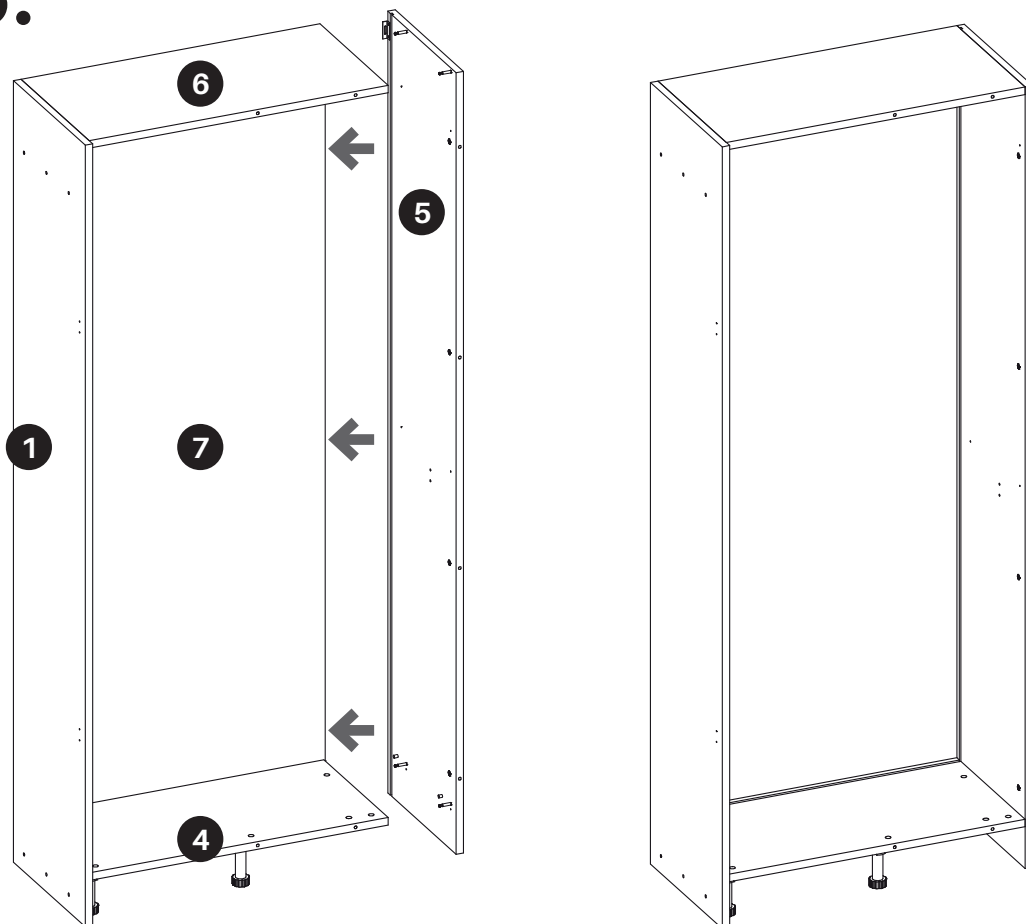
tournevis 



 Serrer les excentriques dans le sens horaire

9.

OUTILS

tournevis

QUINCAILLERIE

Sachet n°834

R	ferrure mâle	x2
F	vis	x4

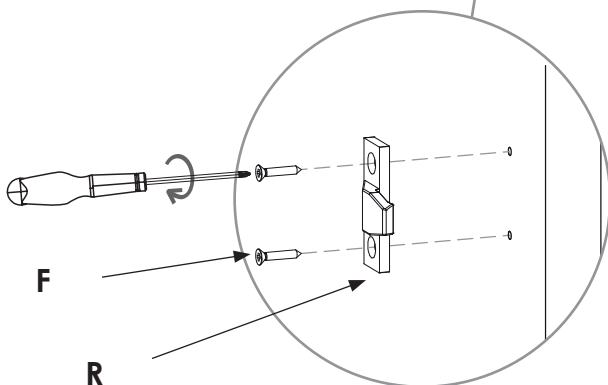

10.

Présentation sans tablette haute.

OUTILS

crayon
perceuse

QUINCAILLERIE

FIXATION MURALE :
VIS ET CHEVILLES NON FOURNIES

⚠ Utiliser des vis, rondelles et chevilles adaptées à votre mur.

ÉTAPE 1

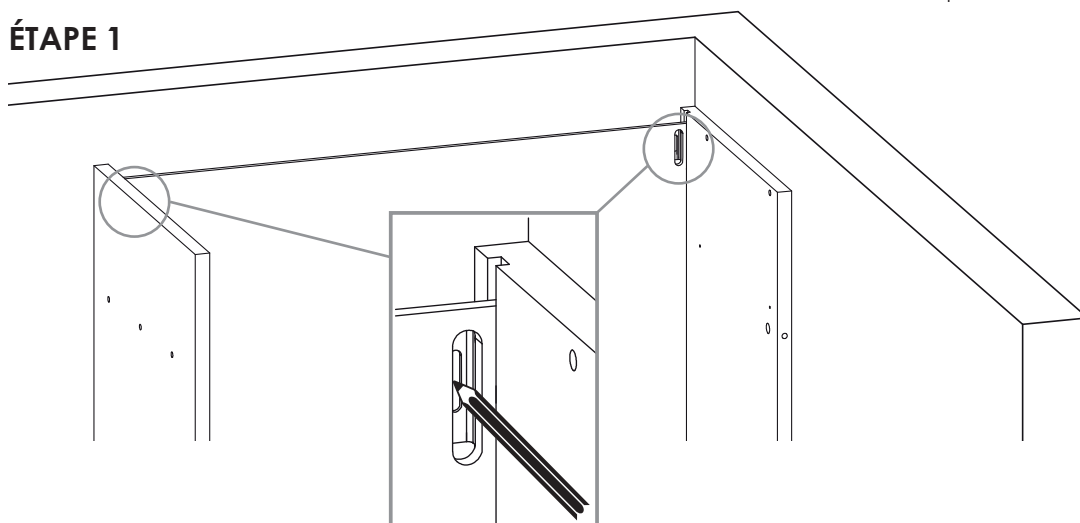

ÉTAPE 2

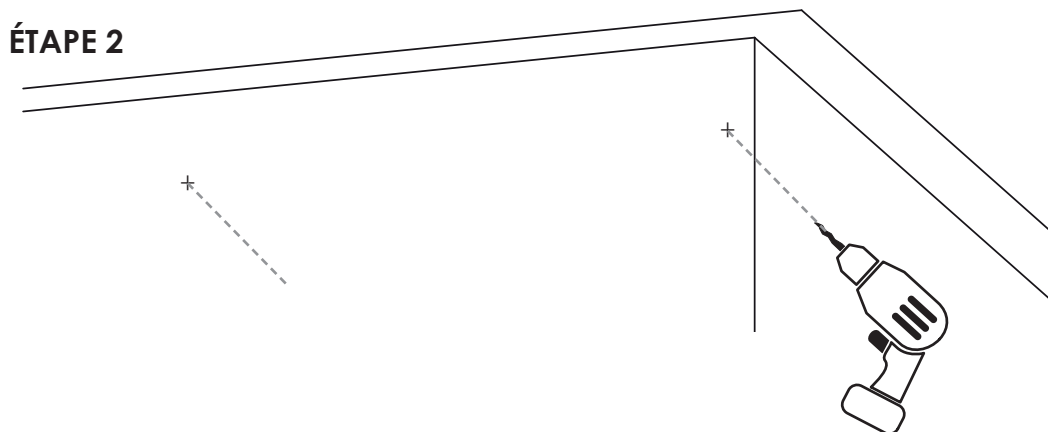

11.

Présentation sans tablette haute.

OUTILS

visseuse

QUINCAILLERIE

FIXATION MURALE :
VIS ET CHEVILLES NON FOURNIES

⚠ Utiliser des vis, rondelles et chevilles adaptées à votre mur.

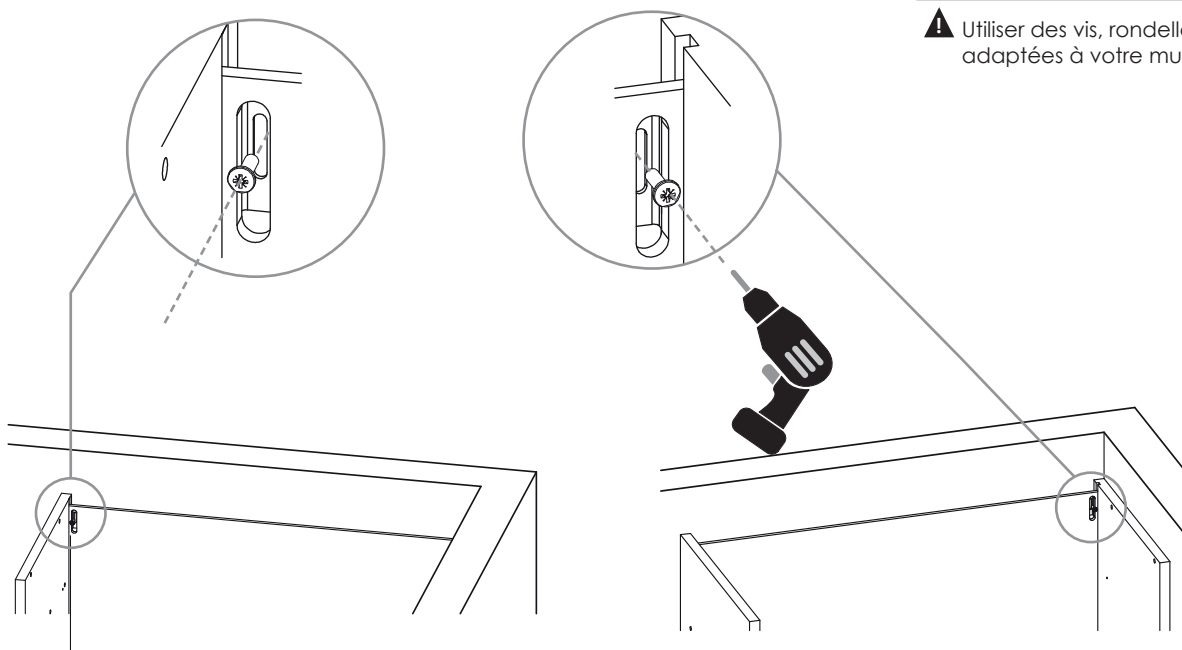

12.

x4

17, 18, 19 et 20

OUTILS

tournevis

QUINCAILLERIE

Sachet n°846		x4
K	excentrique	x12

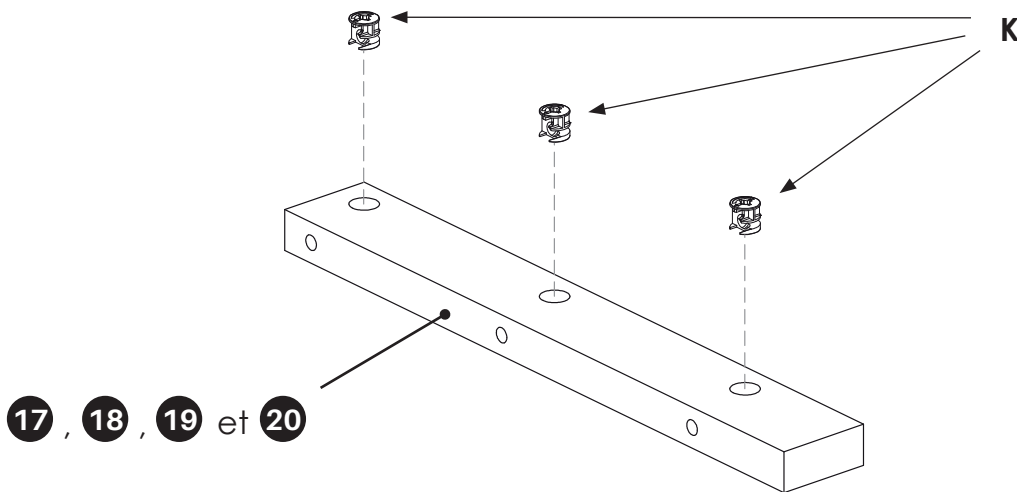

17, 18, 19 et 20

⚠ À l'orientation de la flèche des excentriques.

13.

OUTILS

tournevis



maillet

QUINCAILLERIE

Sachet n°846		x2
D	insert métallique	x6
E	goujon fil métal	x6
Sachet n°834		
R	ferrure mâle	x3
F	vis	x6

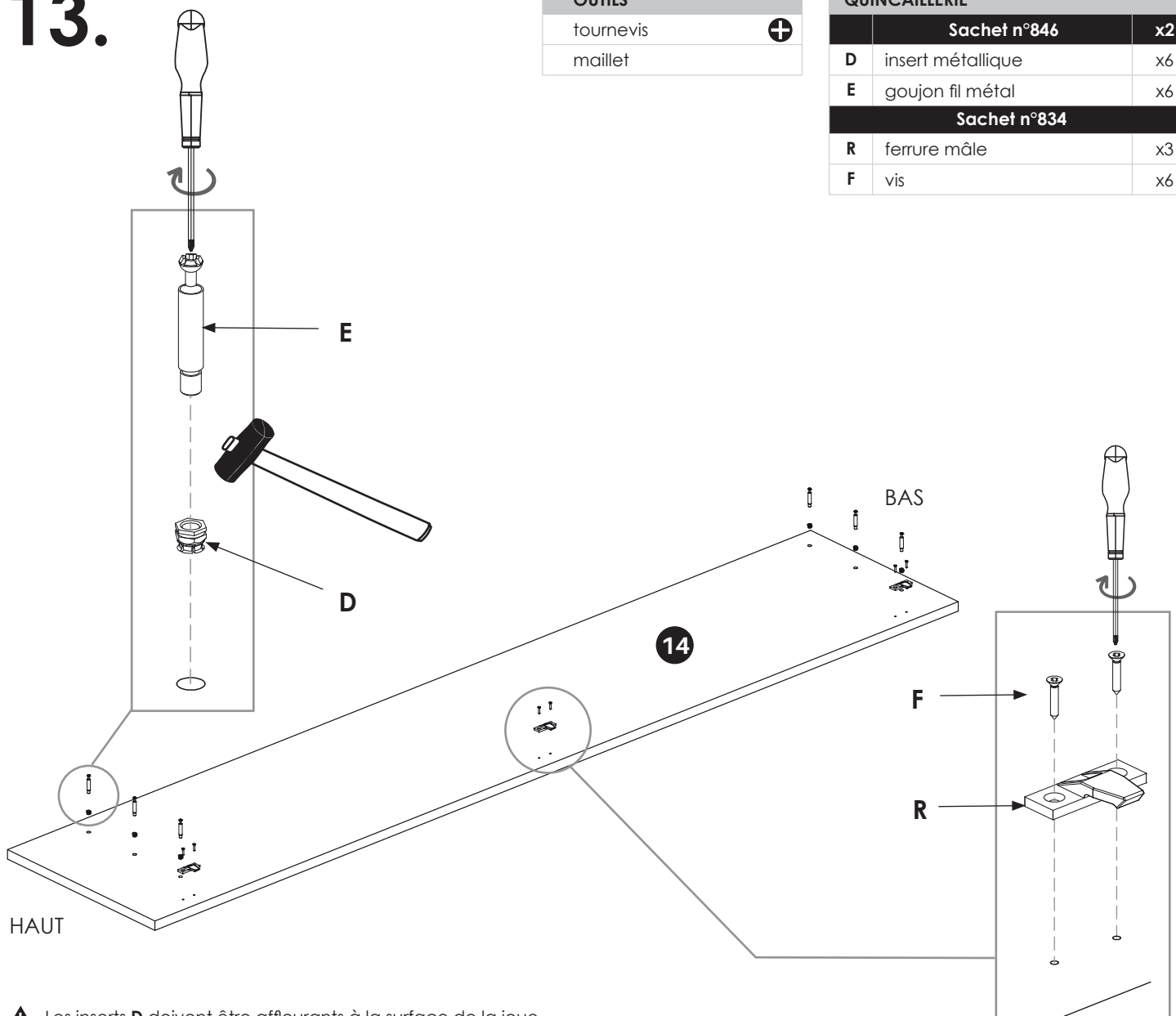

⚠ Les inserts D doivent être affleurants à la surface de la joue.

14.

OUTILS

tournevis



ÉTAPE 1

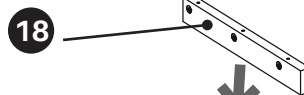
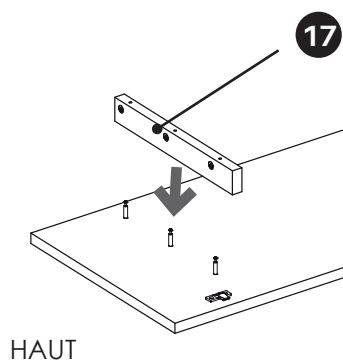

ÉTAPE 2

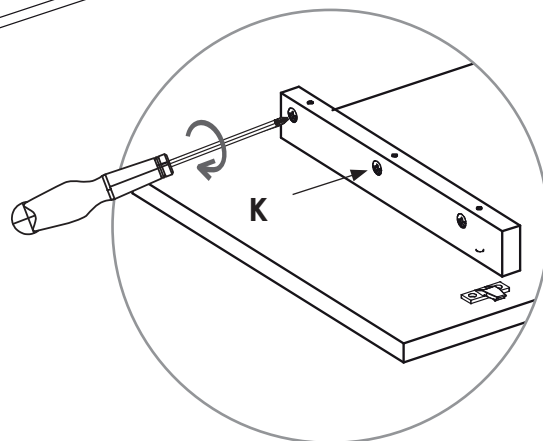

15.

OUTILS

clé 6 pans

QUINCAILLERIE

	Sachet n°846	x2
S	vis	x6

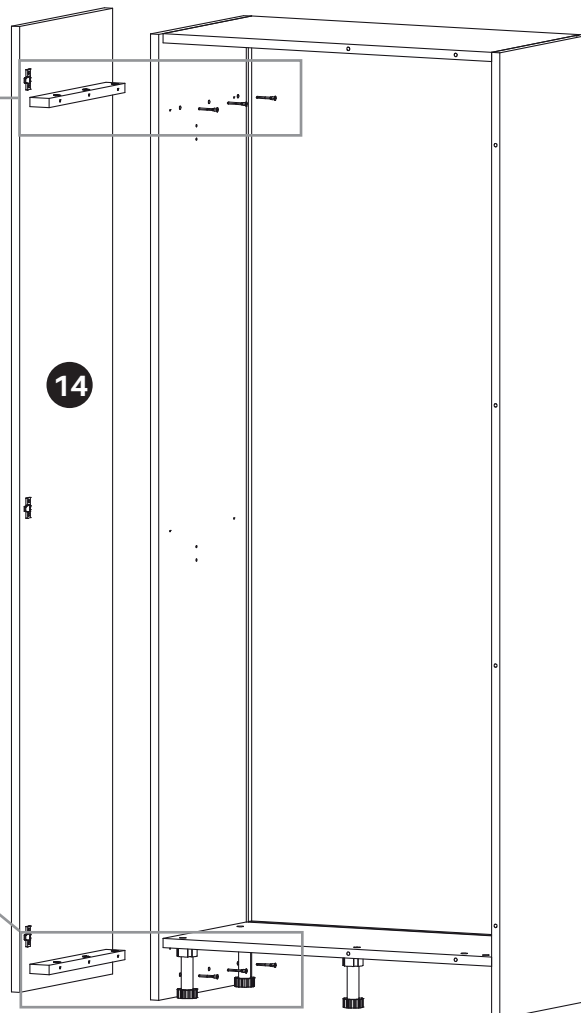
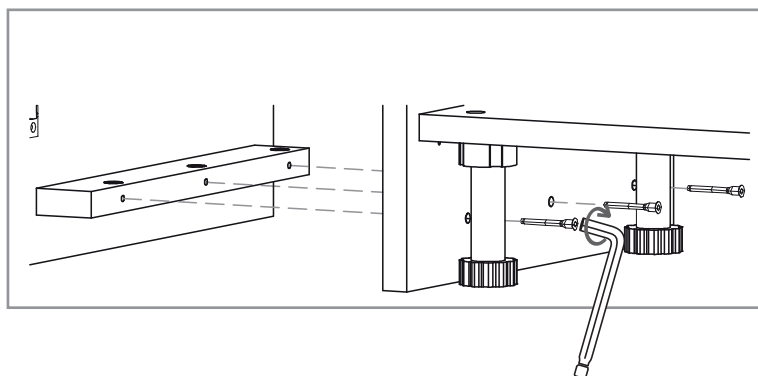
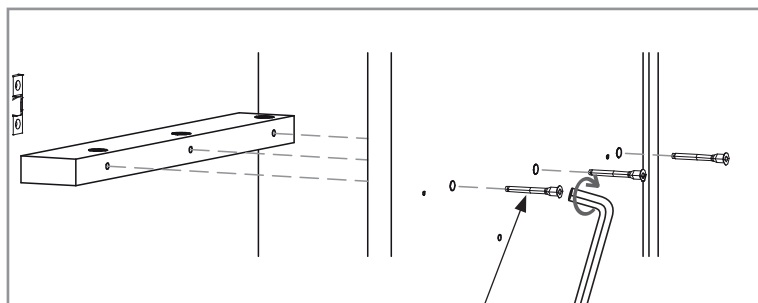

16.

OUTILS

maillet

QUINCAILLERIE**Sachet n°804**

L	boitier	x4
Sachet n°827		1/2
K	excentrique	x2

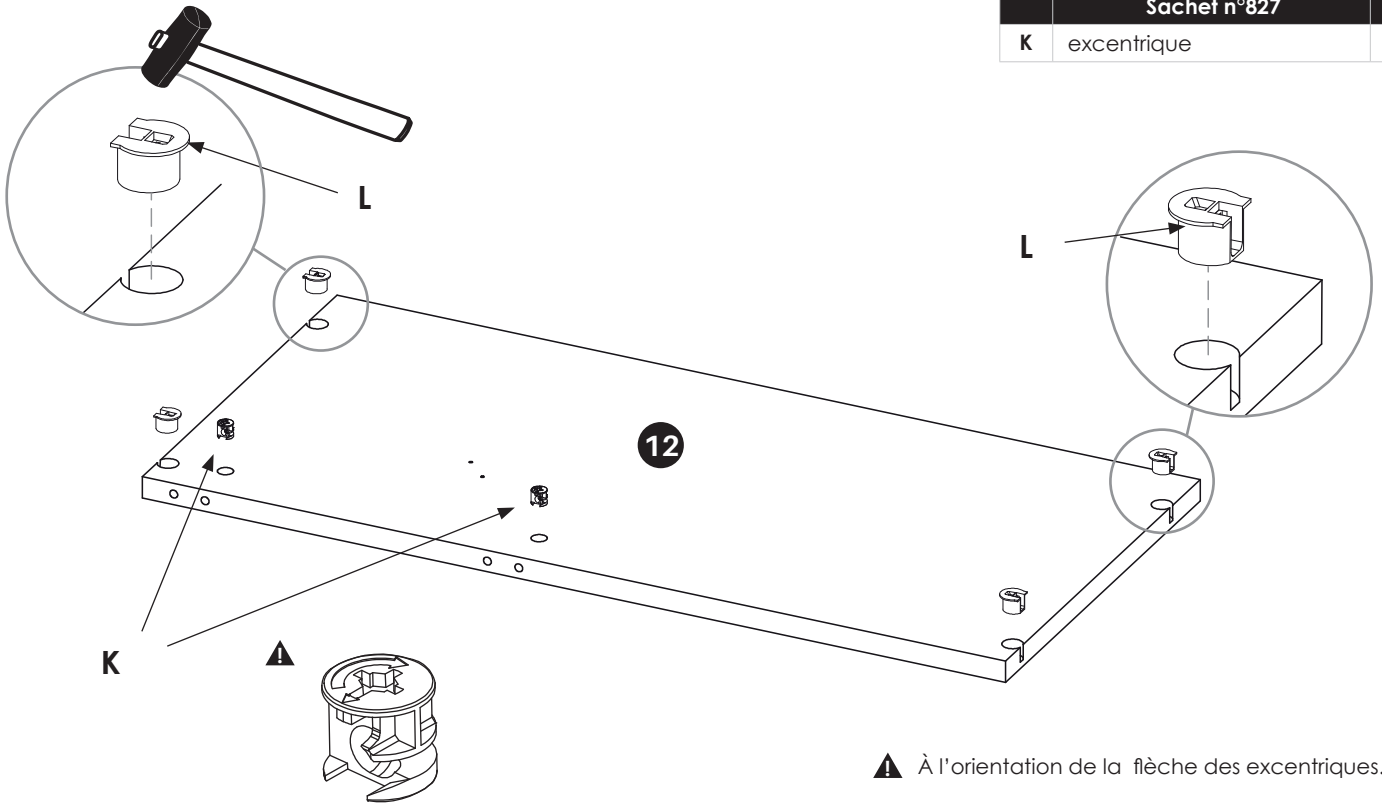

17.

OUTILS

tournevis

**QUINCAILLERIE****Sachet n°804**

M	goujon	x4
---	--------	----

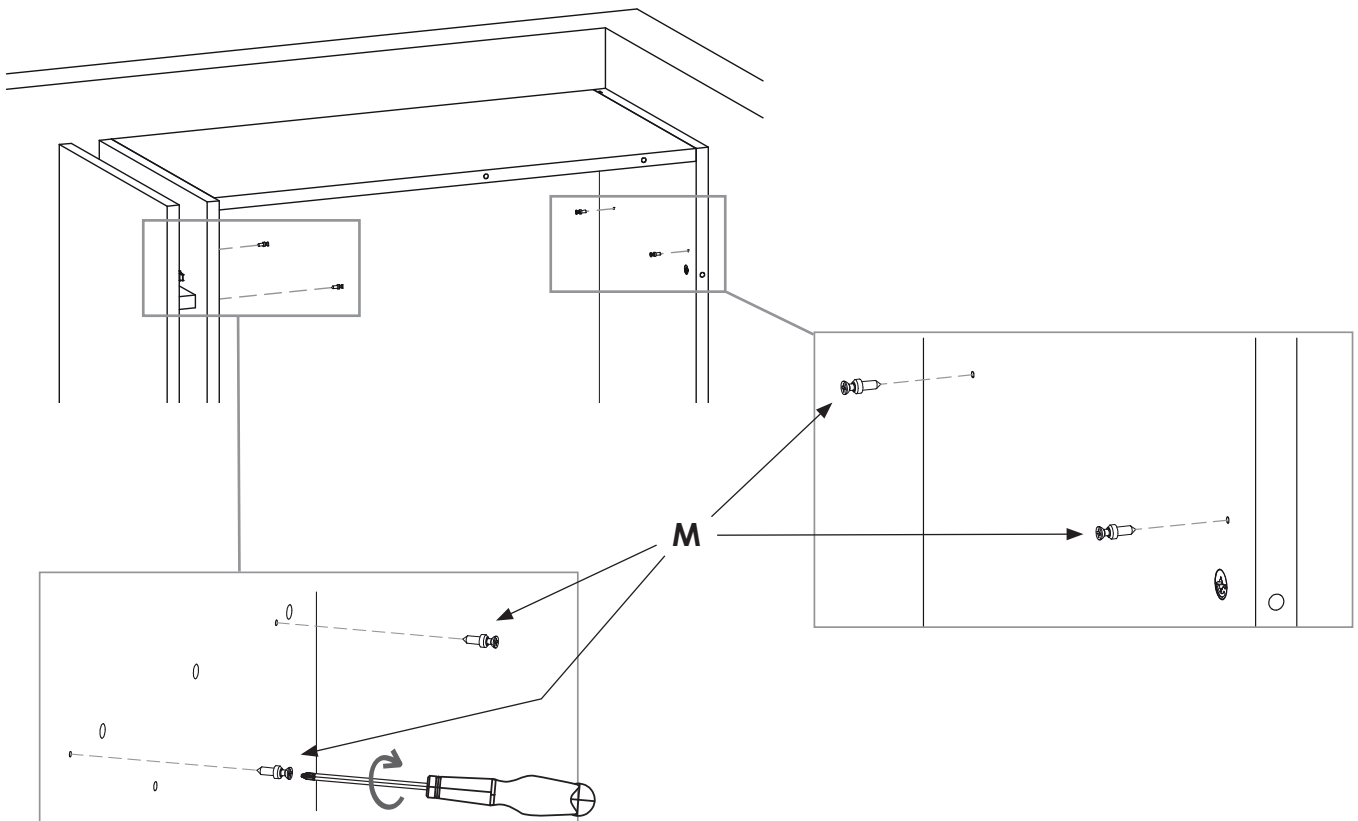

18.

OUTILS

tournevis



ÉTAPE 1

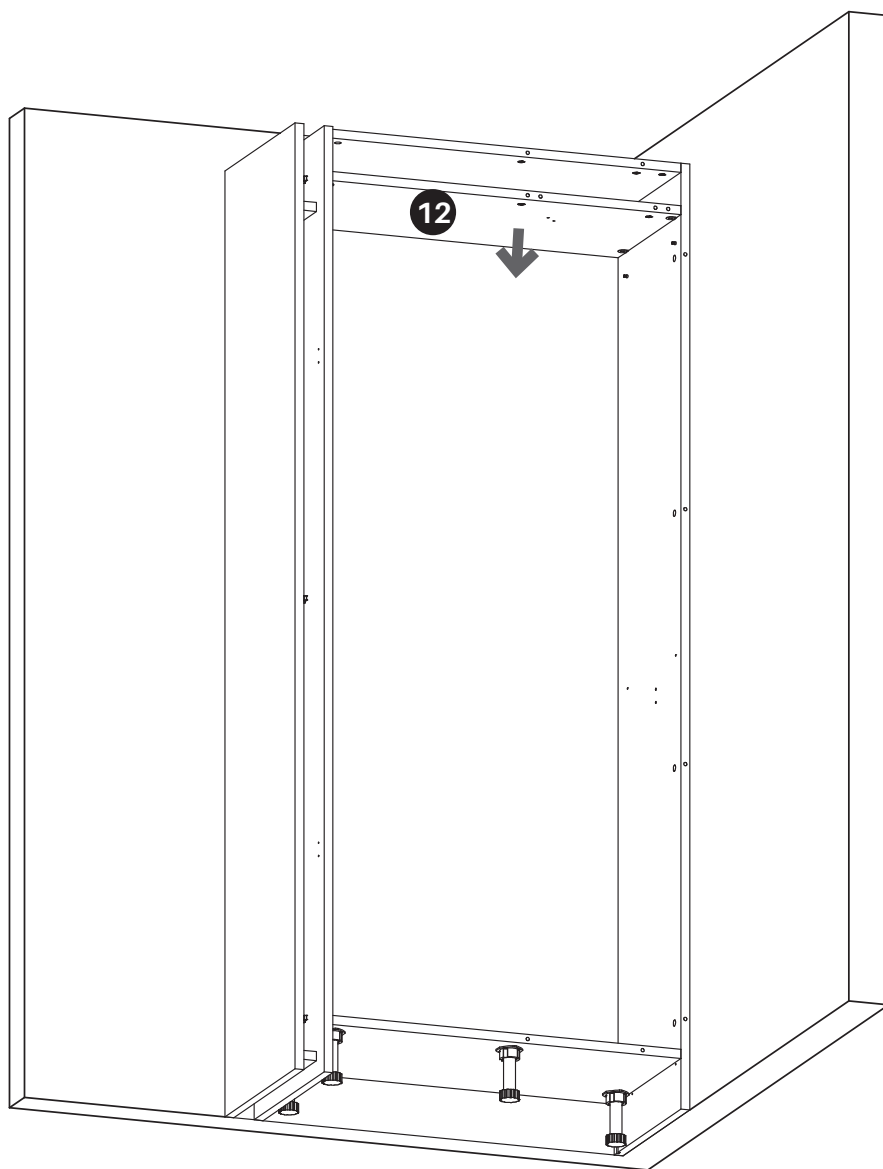

ÉTAPE 2

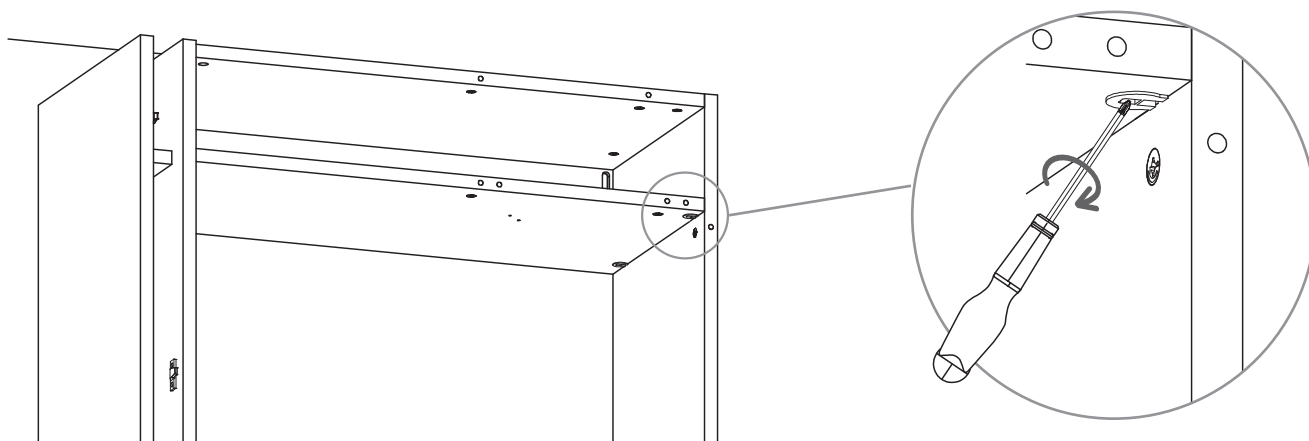

19.

OUTILS

tournevis



QUINCAILLERIE

Sachet n°847

C tourillon x2

T goujon double x2

Sachet n°848

x4

T goujon double x8

⚠ Pensez à retirer les circlips sur les goujons double avant utilisation.

Le goujon double peut être inséré dans n'importe quel sens.

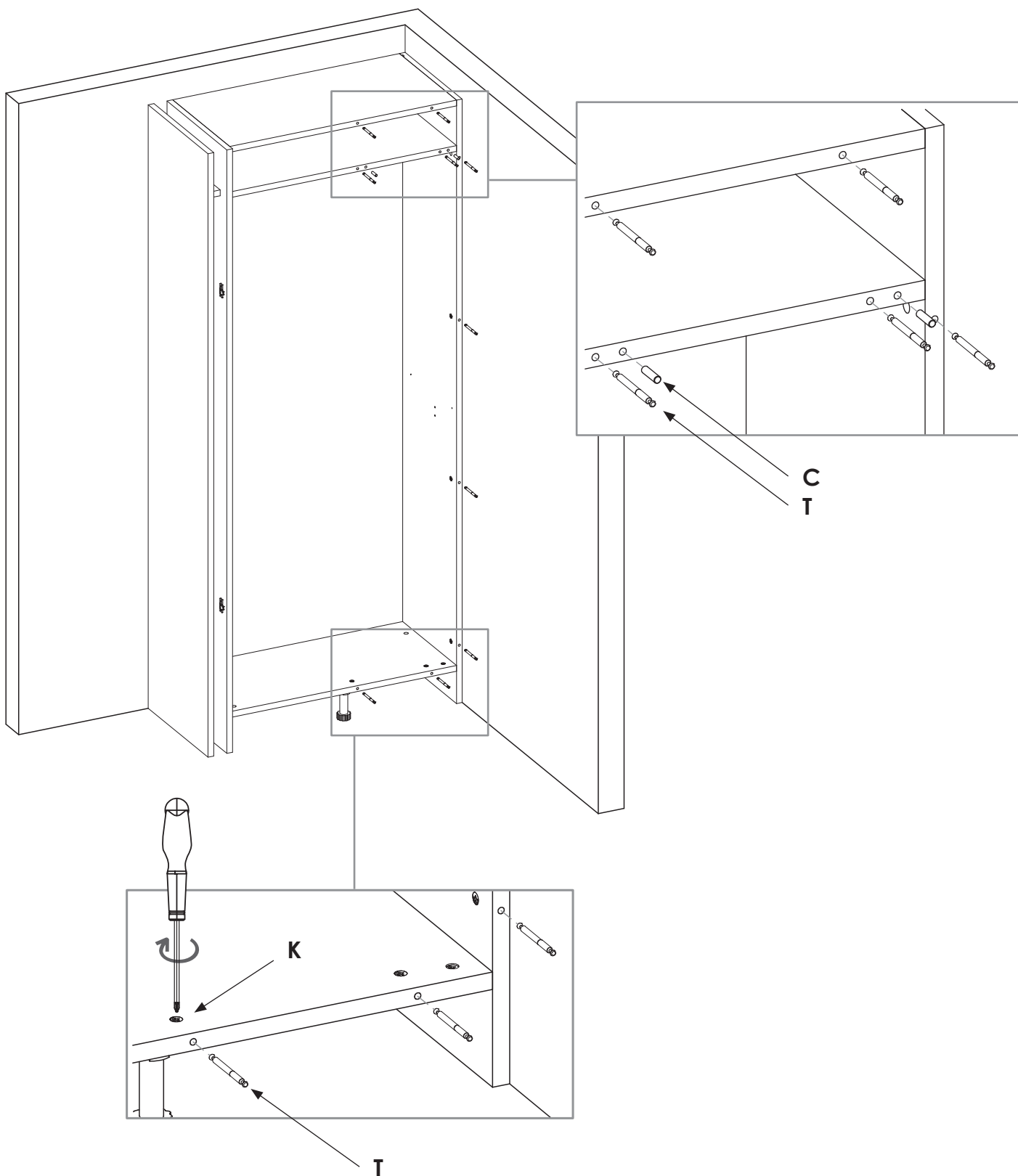
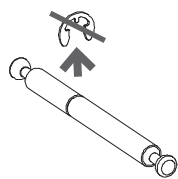

20.

QUINCAILLERIE

Sacnet n°827		
K	excentrique	x8

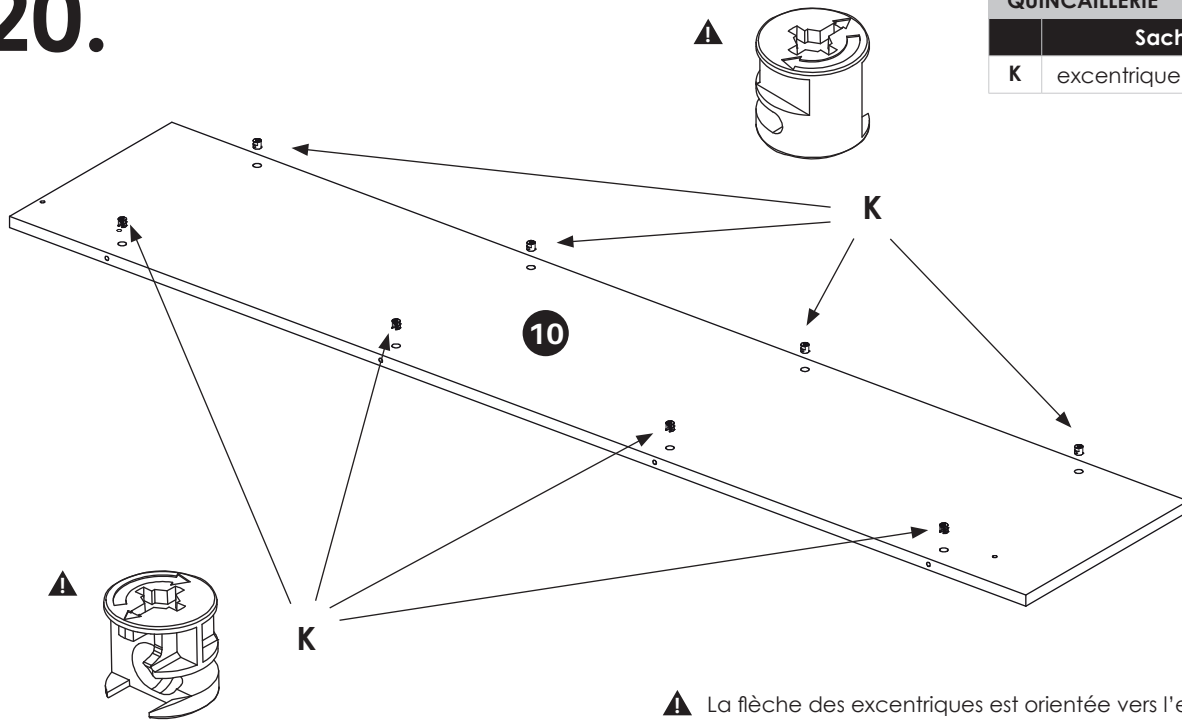

⚠ La flèche des excentriques est orientée vers l'extérieur de la joue.

21.

OUTILS

tournevis	+
maillet	

QUINCAILLERIE

Sacnet n°849		
D	insert métallique	x8
E	goujon fil métal	x8
C	tourillon	x6

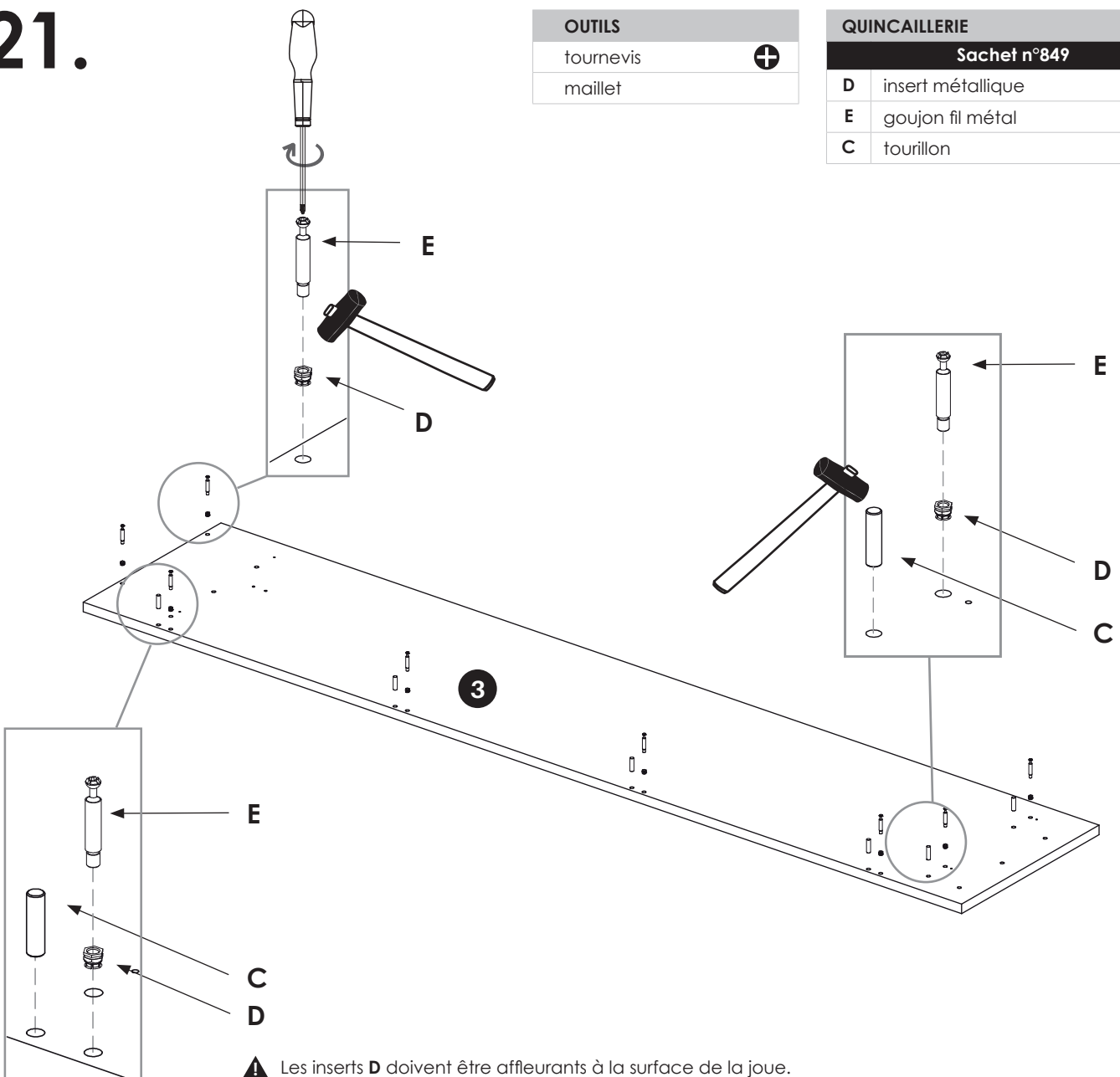

⚠ Les inserts D doivent être affleurants à la surface de la joue.

22.

OUTILS

tournevis



ÉTAPE 1

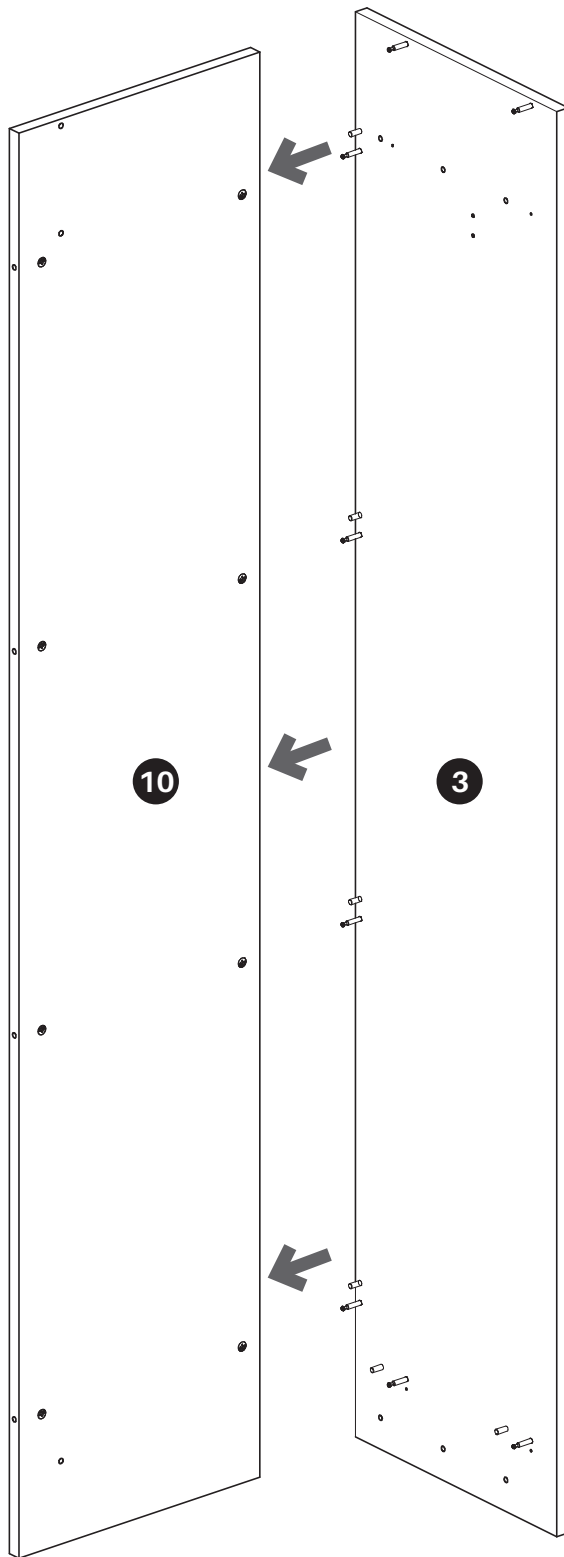

ÉTAPE 2

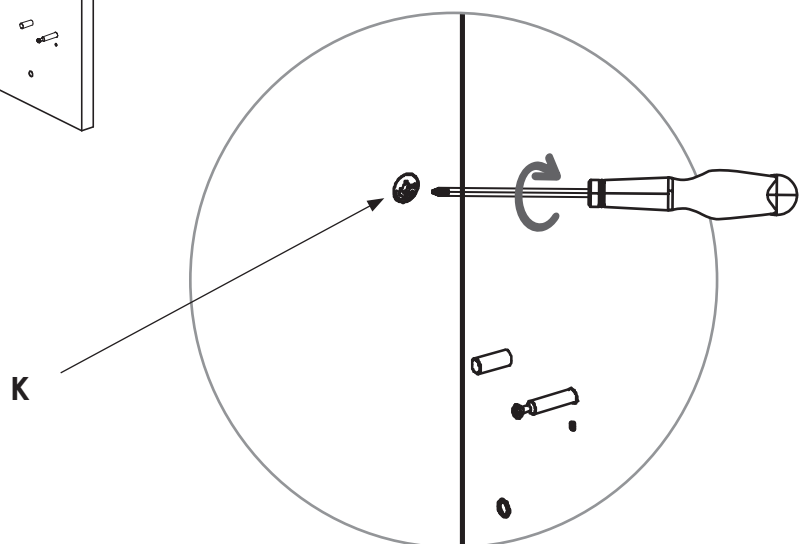

23.

OUTILS

tournevis	+
maillet	

QUINCAILLERIE

Sachet n°846		
D	insert métallique	x6
E	goujon fil métal	x6
Sachet n°834		
R	ferrure mâle	x2
F	vis	x4

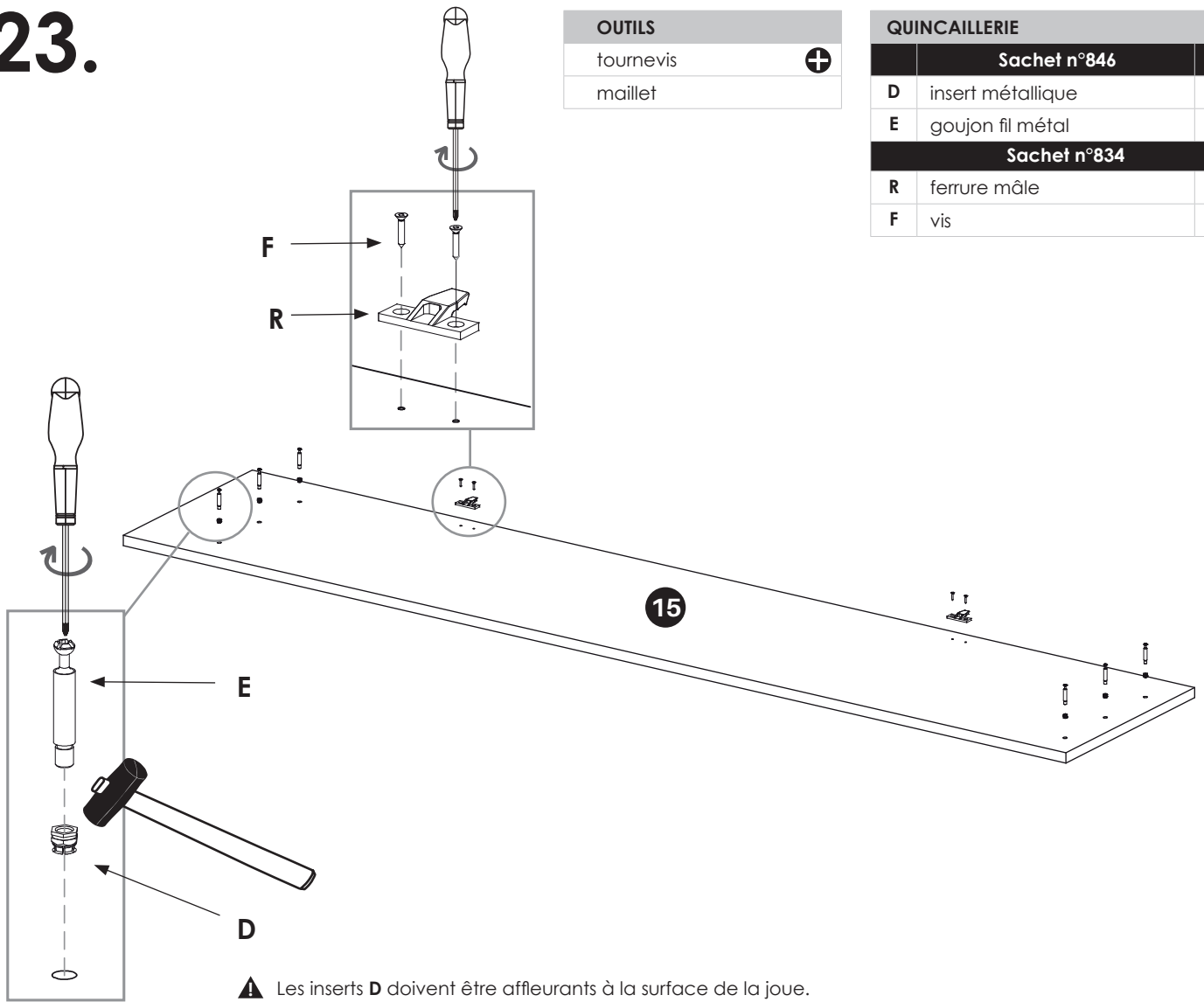

24.

OUTILS

tournevis	+
-----------	---

ÉTAPE 1

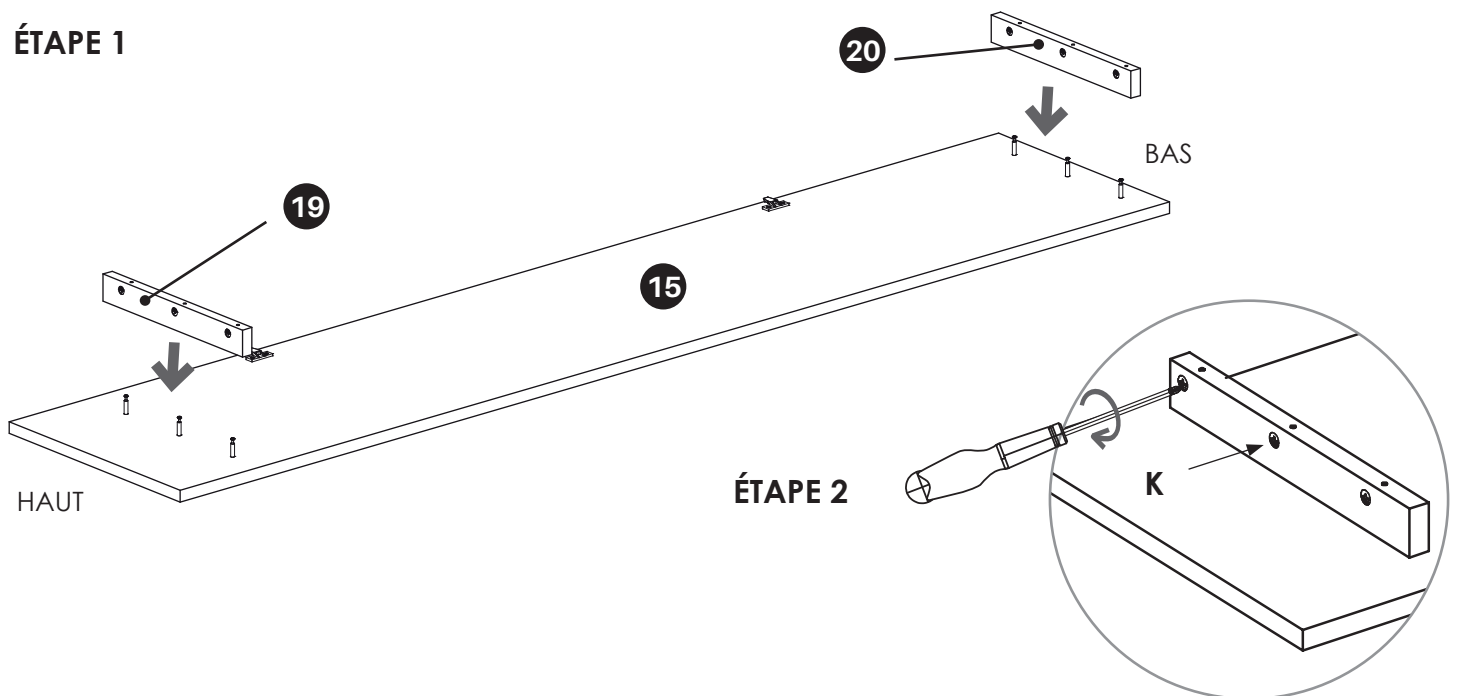

25.

OUTILS

clé 6 pans

tournevis



QUINCAILLERIE

Sachet n°846

S	vis	x6
---	-----	----

Sachet n°847

M	goujon	x2
---	--------	----

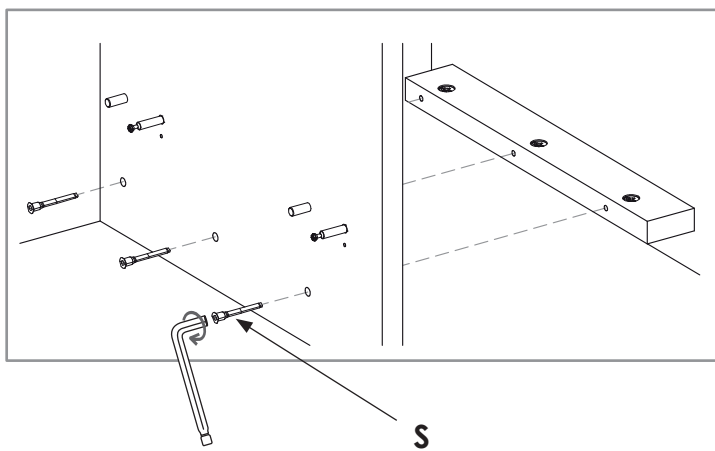
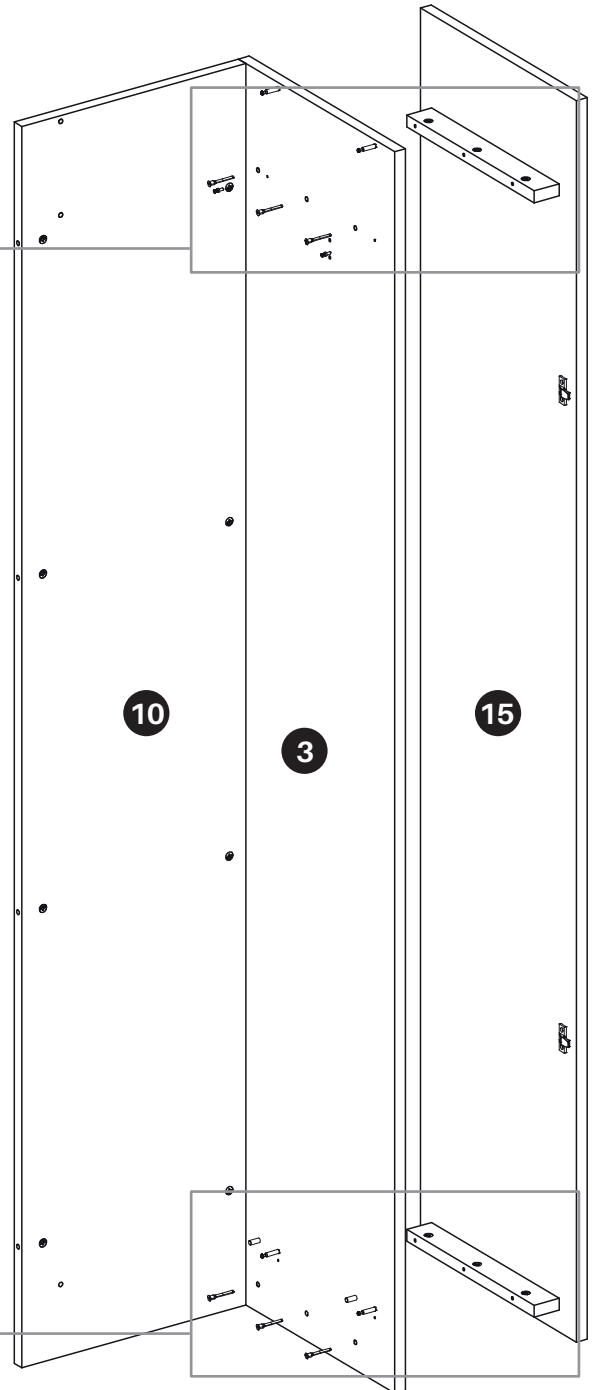
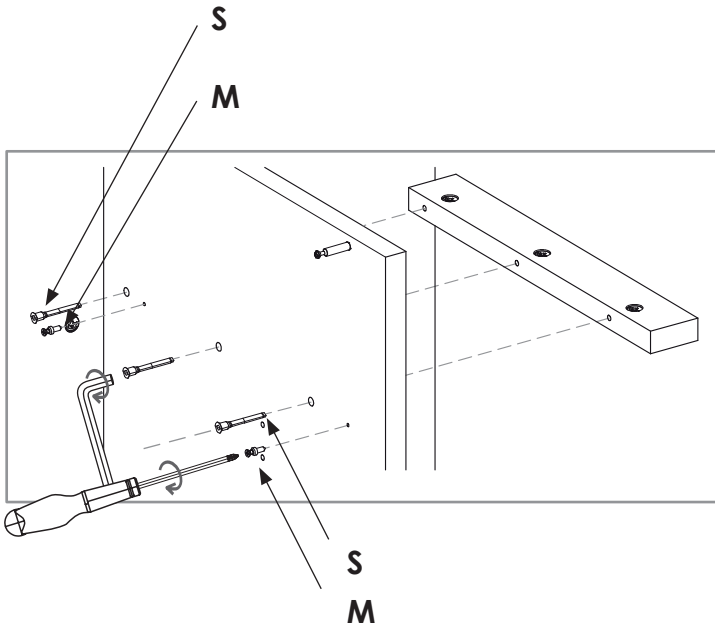

26.

QUINCAILLERIE

Sachet n°827

K	excentrique	x4
---	-------------	----

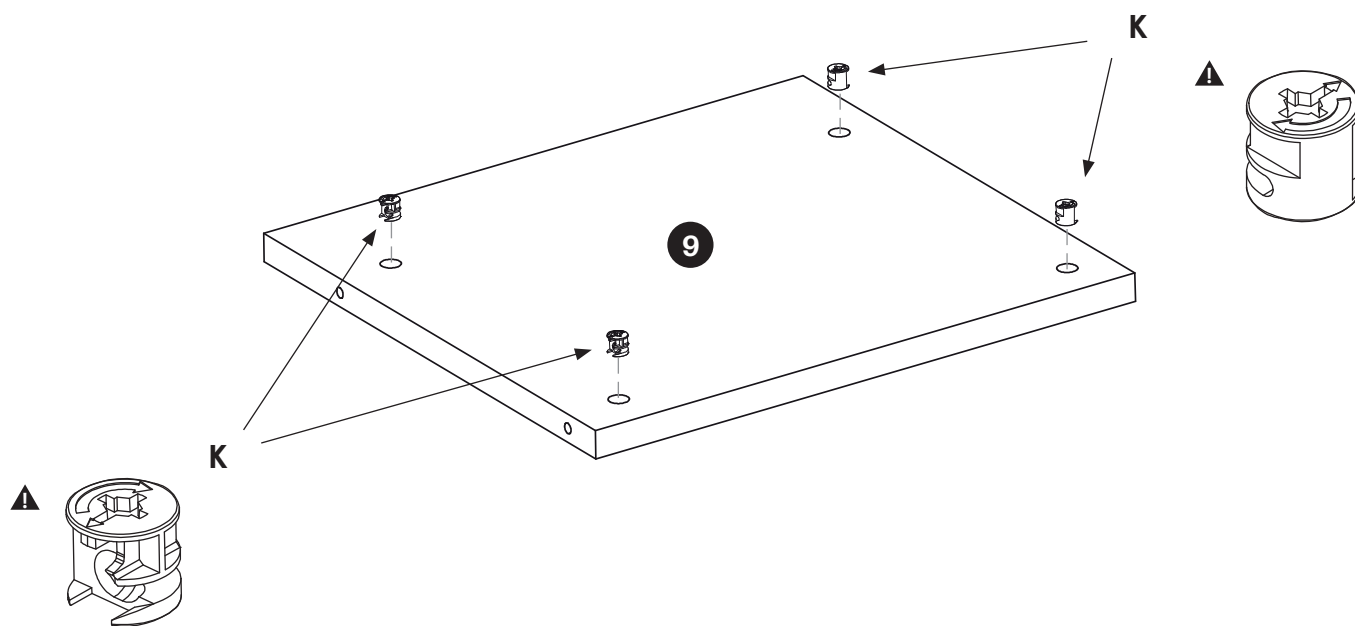

⚠ La flèche des excentriques est orientée vers l'extérieur de la tablette.

27. ↻

OUTILS

tournevis



QUINCAILLERIE

Sachet n°826

I	embase	x4
J	piéd	x4
F	vis	x16

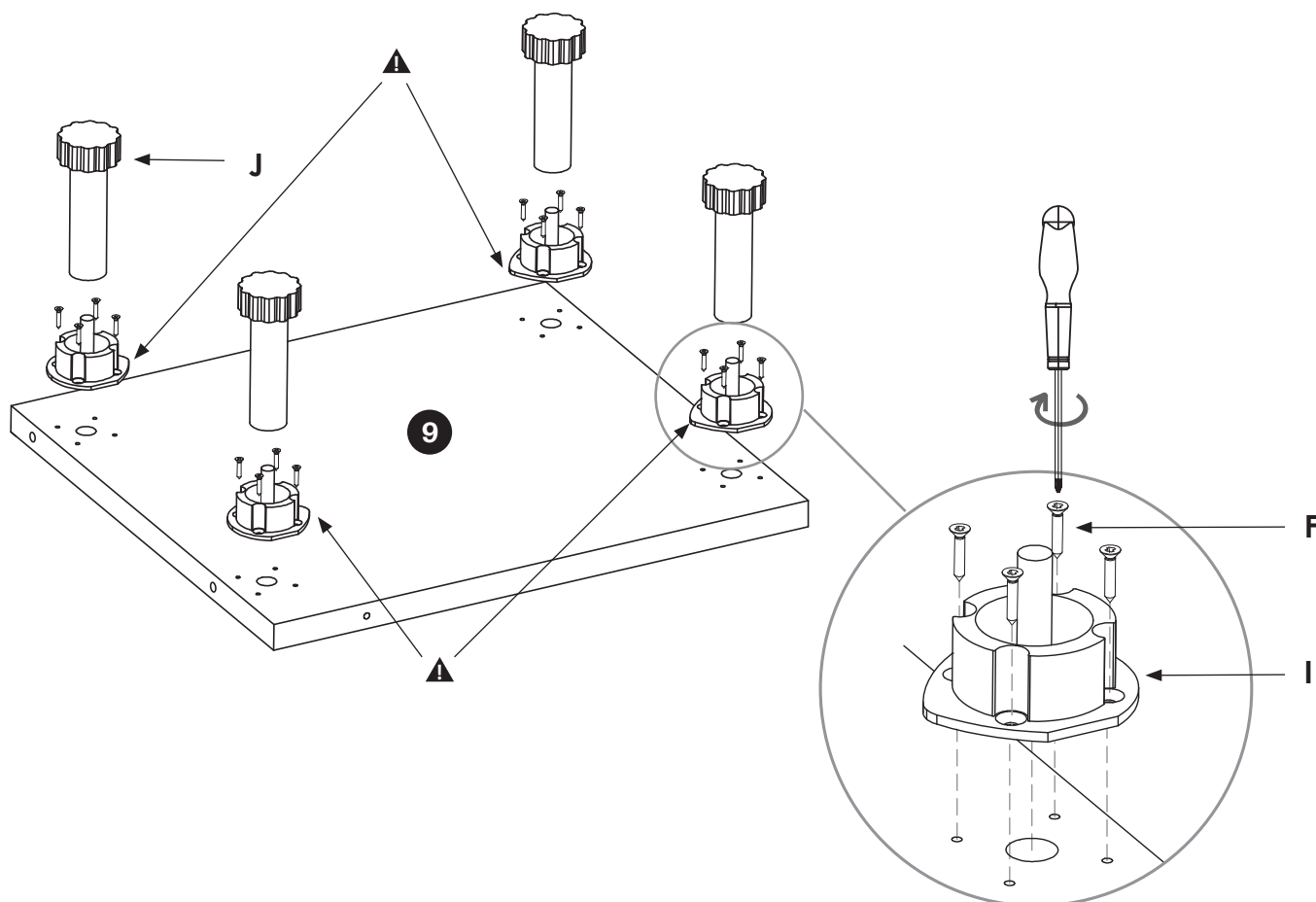

⚠ Les embases doivent être positionnées avec la pointe vers l'intérieur de la tablette.

28.

QUINCAILLERIE

Sachet n°827

K	excentrique	x4
---	-------------	----

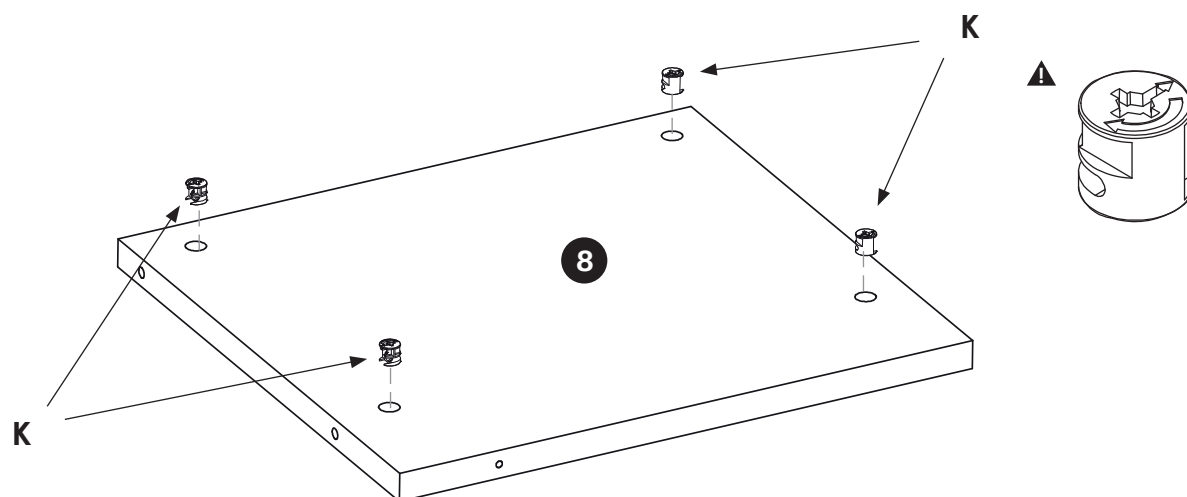

⚠ La flèche des excentriques est orientée vers l'extérieur de la tablette.

29.

OUTILS

maillet

QUINCAILLERIE

Sachet n°827

1/2

K	excentrique	x2
---	-------------	----

Sachet n°847

L	boîtier	x2
---	---------	----

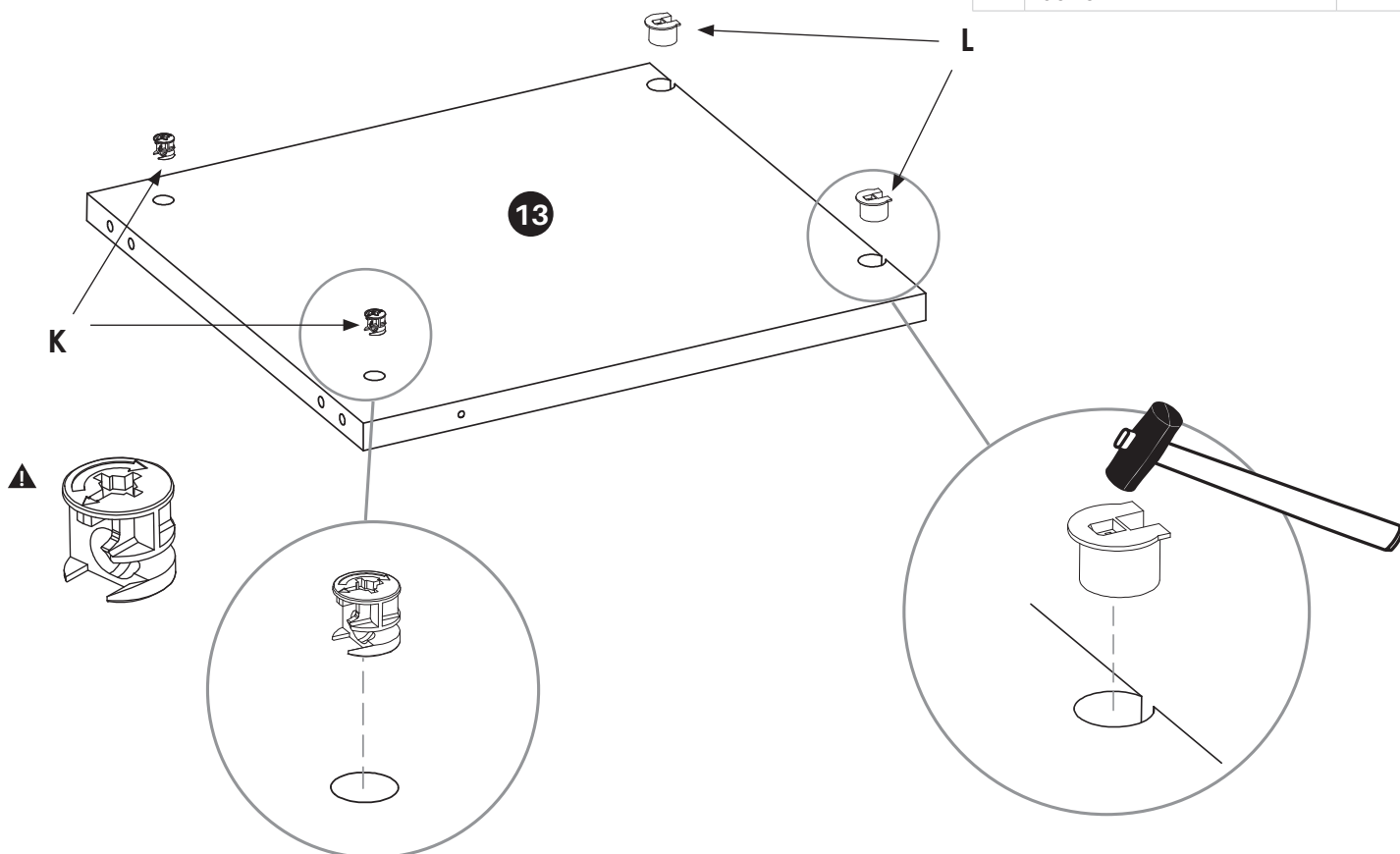

⚠ La flèche des excentriques est orientée vers l'extérieur de la tablette.

30.

Réaliser cette étape à proximité de l'ensemble préalablement monté, afin de limiter les déplacements à l'étape 31.

OUTILS

tournevis



clé 6 pans

QUINCAILLERIE

Sacnet n°832

S

vis

x3

Dans le sacnet **832**, il restera 3 vis non utilisées.

ÉTAPE 1

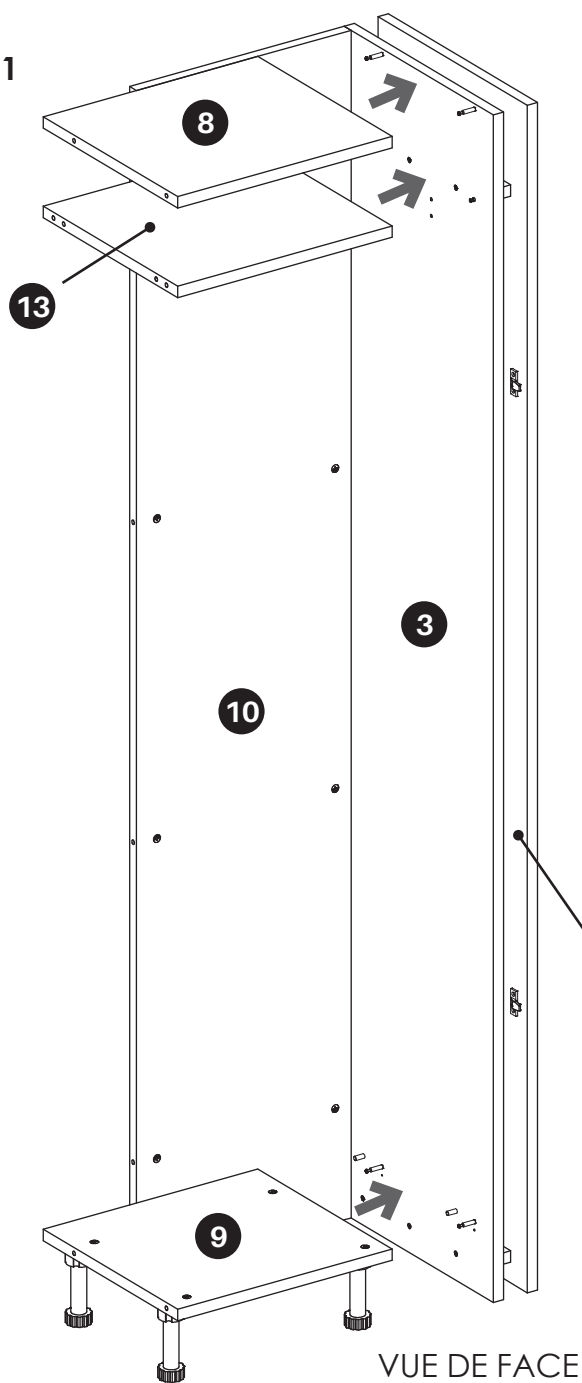

ÉTAPE 3

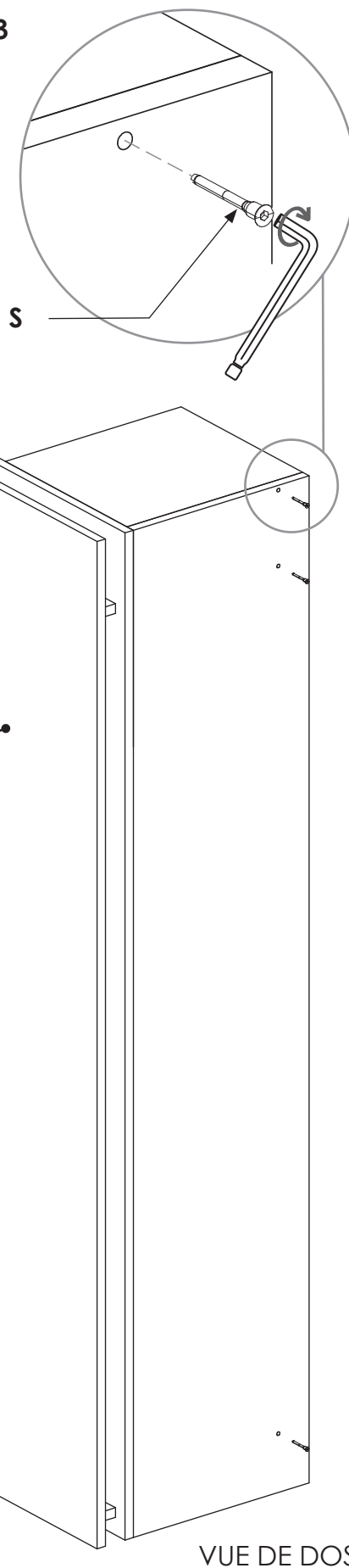

ÉTAPE 2

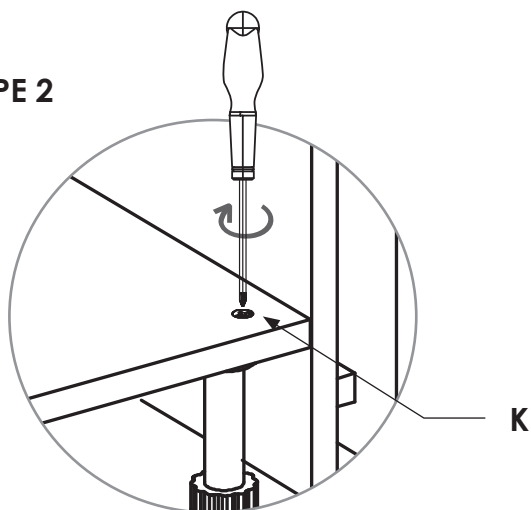

31.

OUTILS

tournevis



ÉTAPE 1

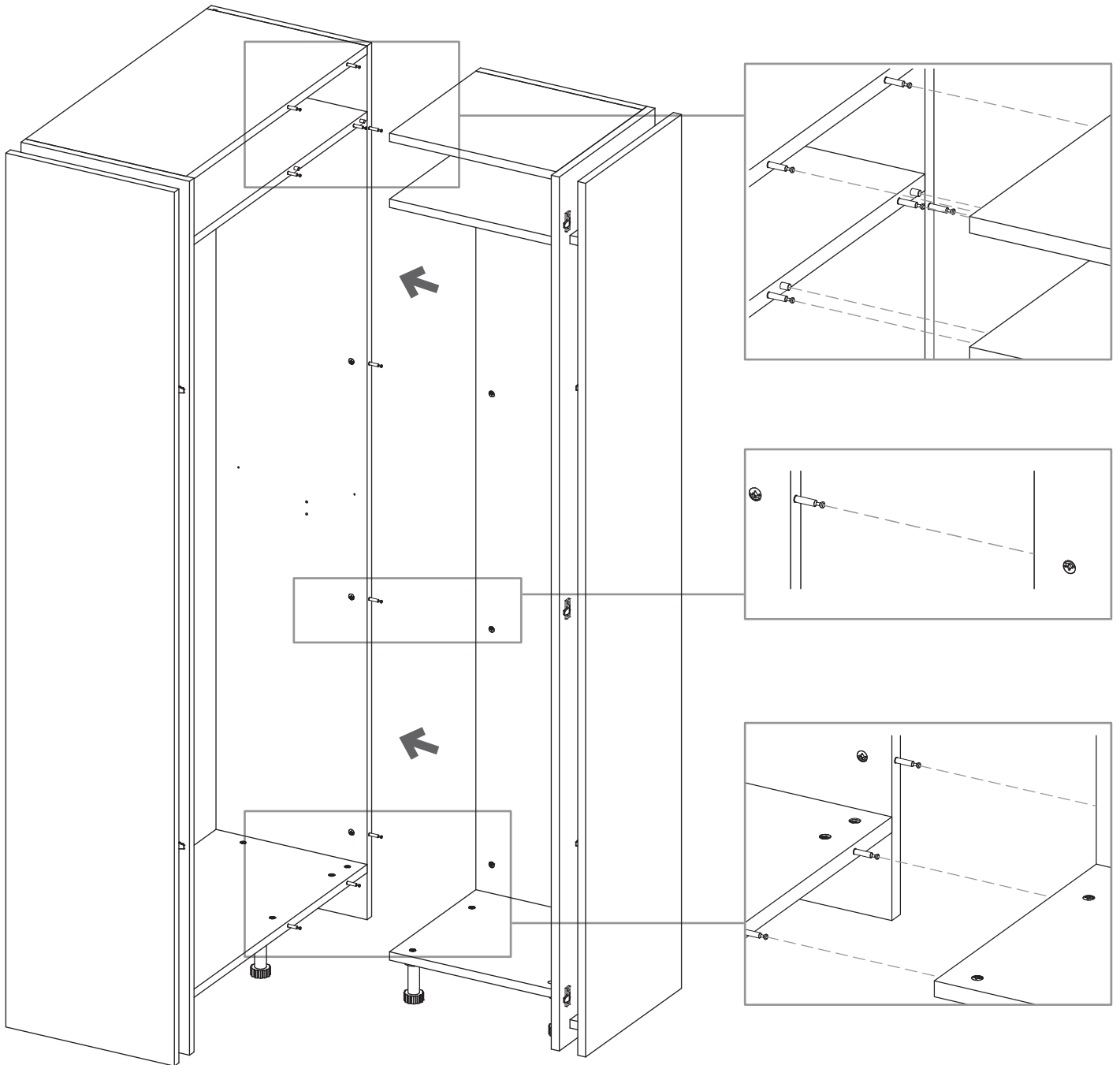

ÉTAPE 2

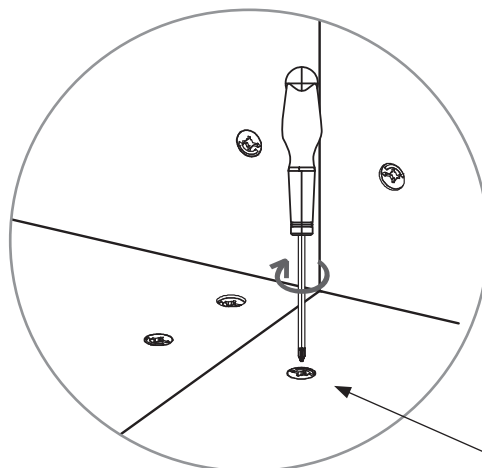

K

32.

OUTILS

tournevis



QUINCAILLERIE

	Sachet n°801	x2
G	clip de plinthe	x4
H	support clip de plinthe	x4
F	vis	x8

ÉTAPE 1

x2

23 et 24

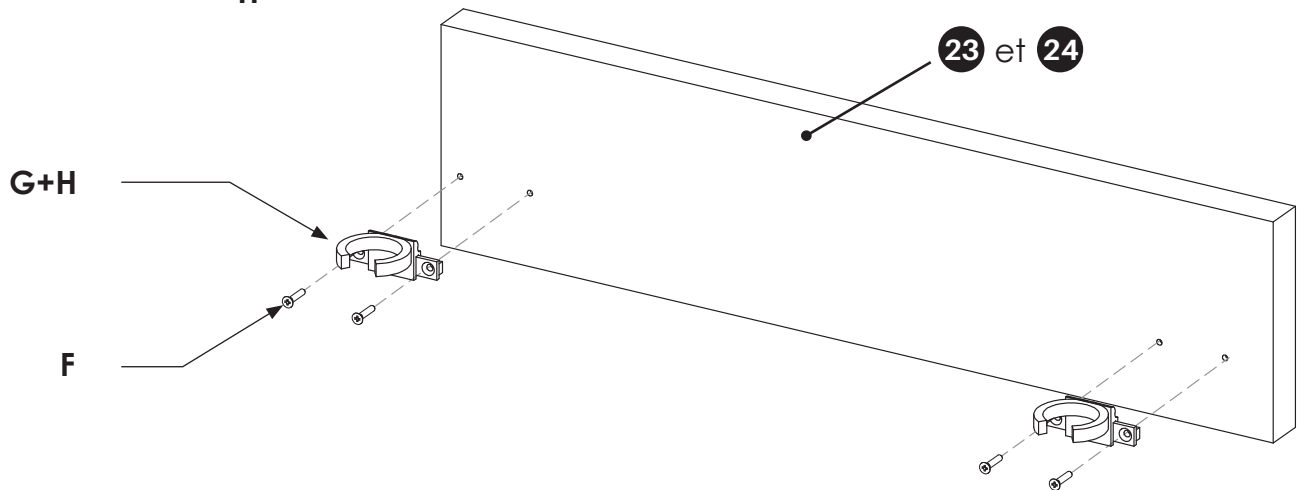
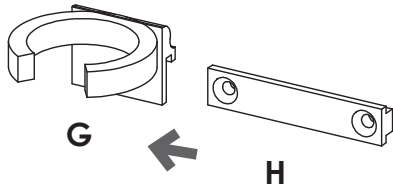

ÉTAPE 2

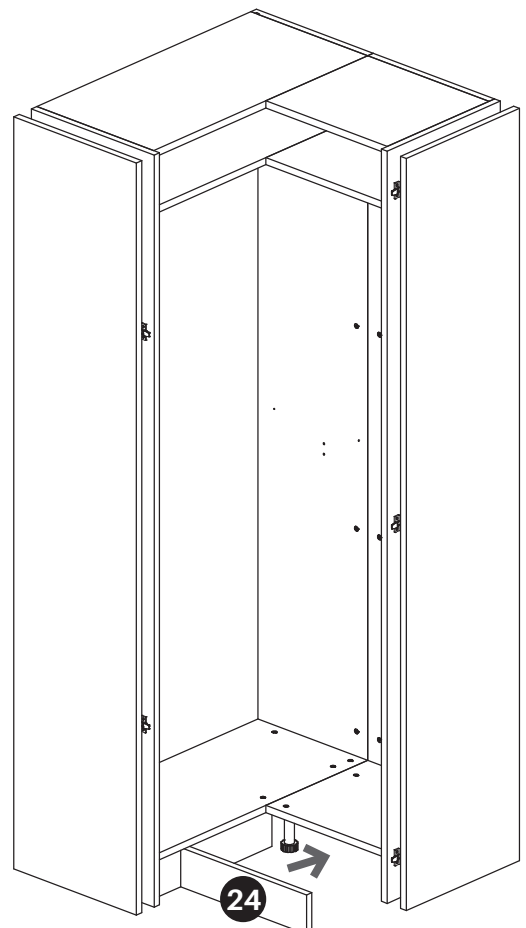
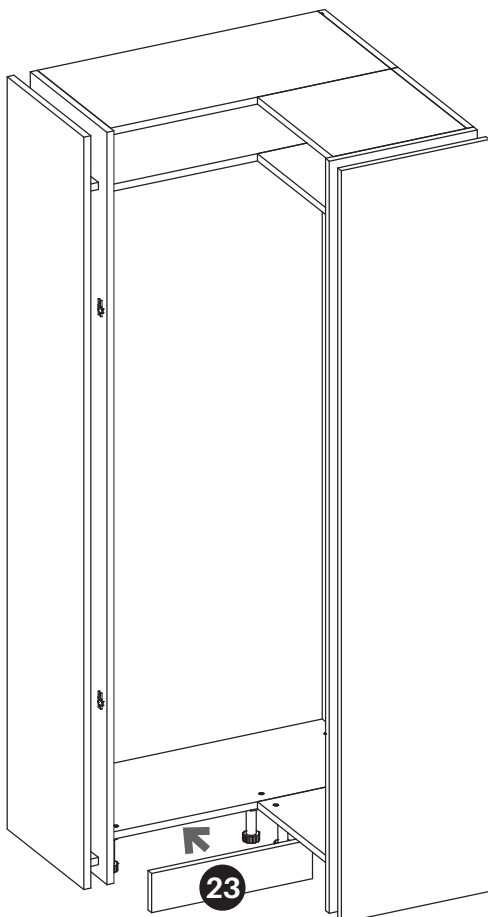

33.

OUTILS

tournevis



QUINCAILLERIE

Sachet n°828

P	support tringle	x2
F	vis	x2

⚠ Les vis sont à visser sans pré-perçage préalable.

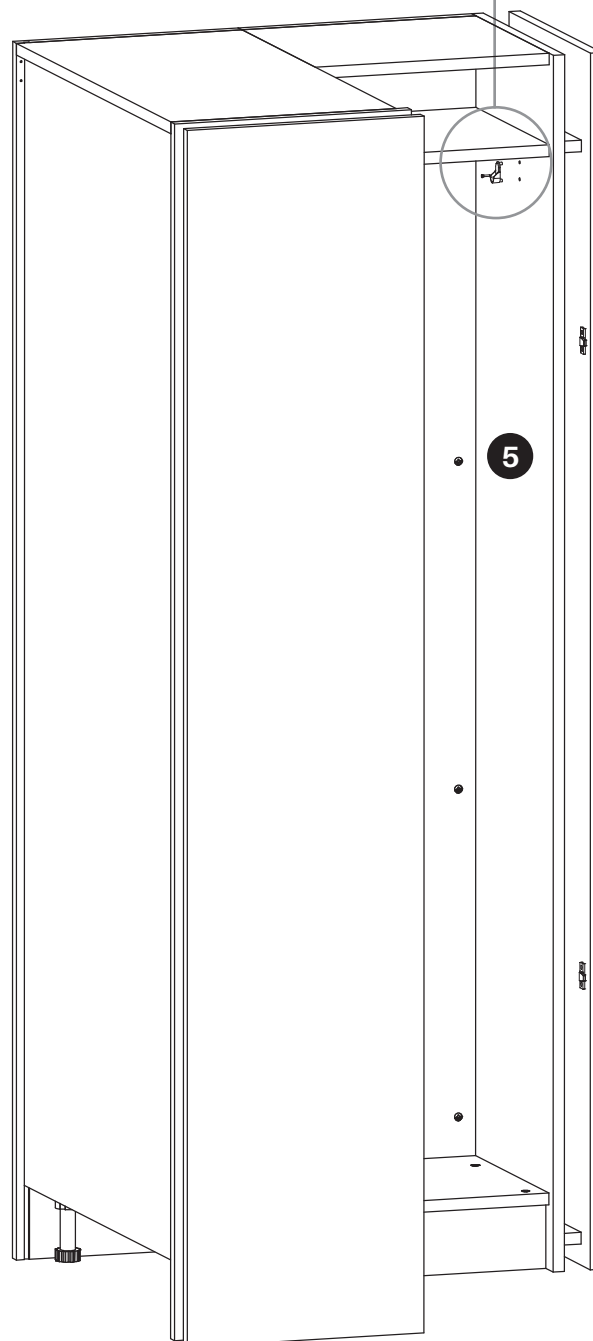
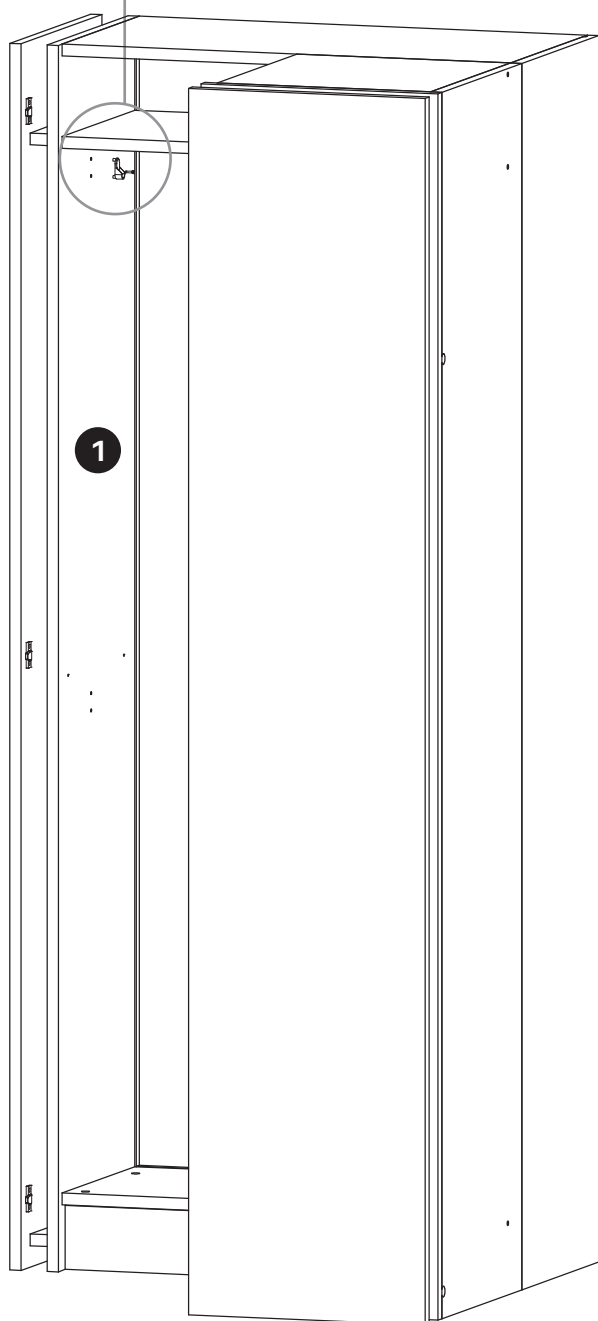
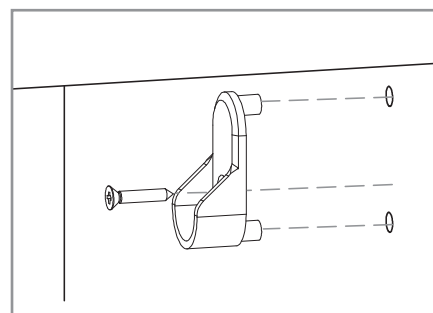
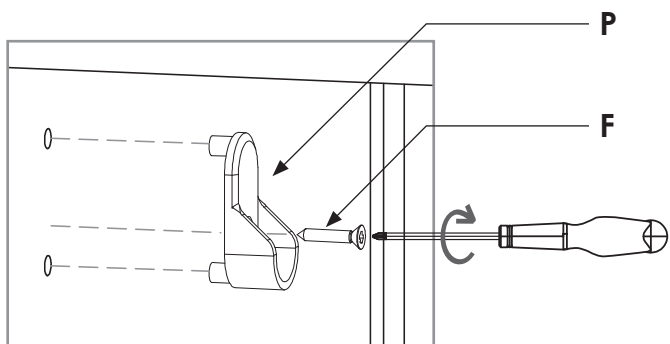

34.

OUTILS

tournevis



QUINCAILLERIE

Sachet n°850

U	coude de jonction	x1
V	support sous tablette	x1
F	vis	x2

ÉTAPE 1

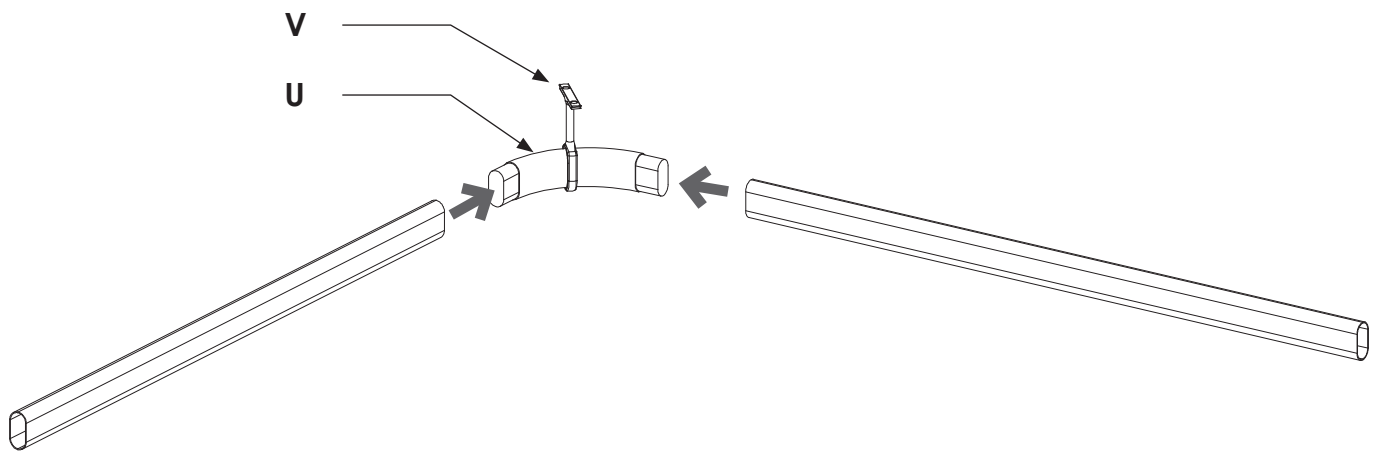

ÉTAPE 2

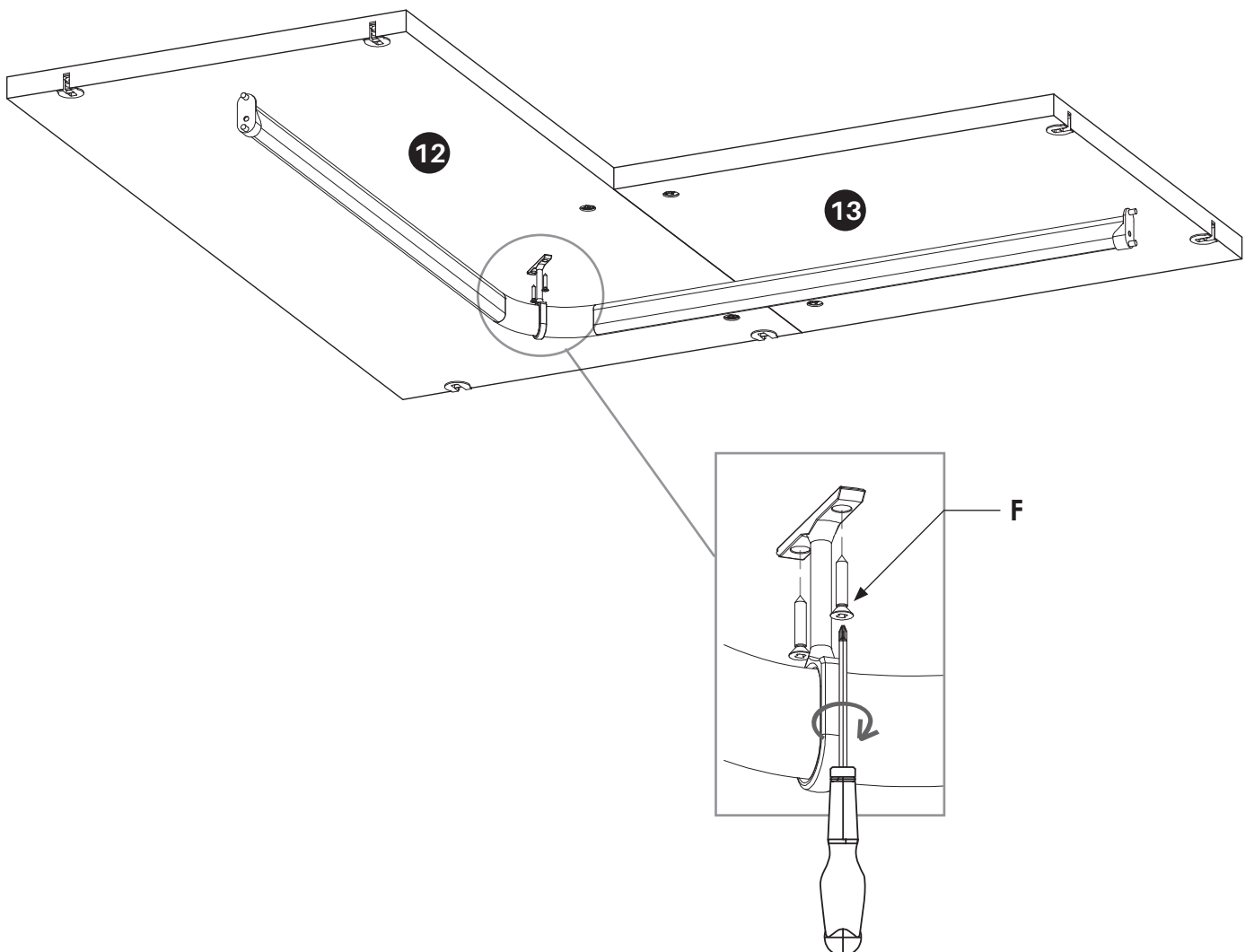

35.

OUTILS

maillet

tournevis



QUINCAILLERIE

Sachet n°804

L

boitier

x4

Sachet n°804

M

goujon

x4

ÉTAPE 1

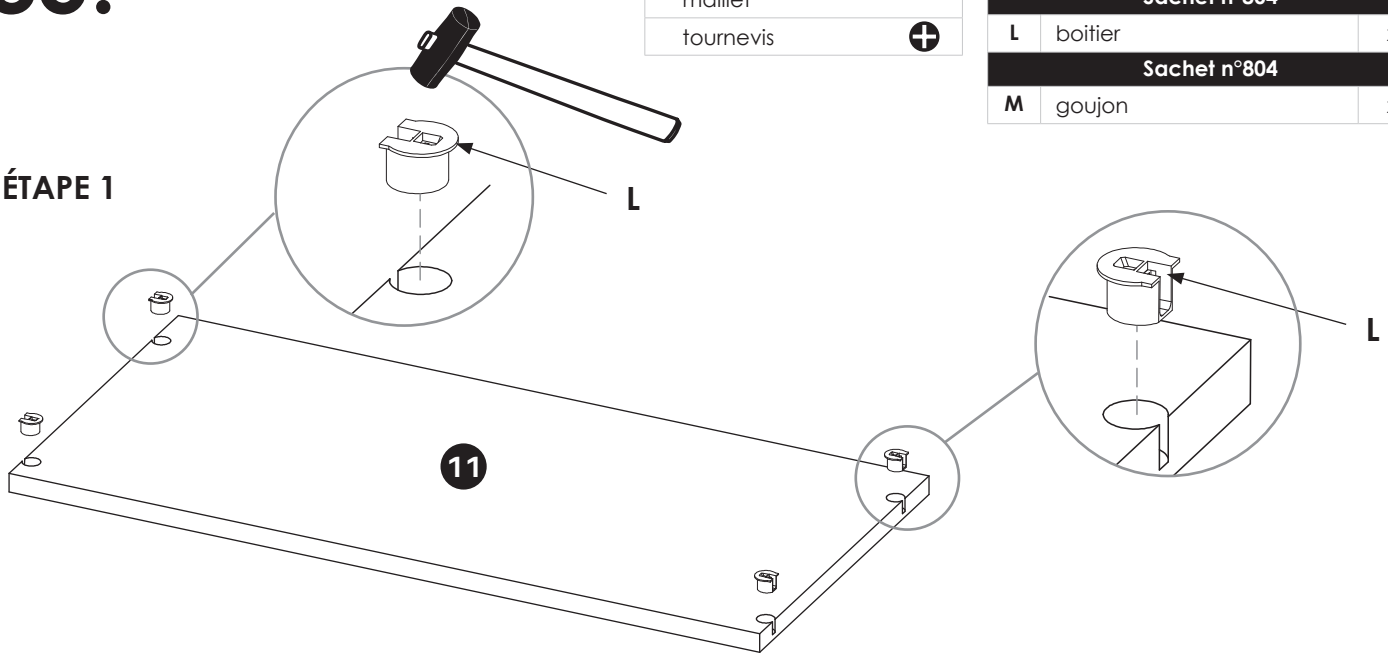

ÉTAPE 2 : Répéter les étapes 17. et 18.

36.

OUTILS

tournevis



QUINCAILLERIE

Sachet n°828

P

support tringle

x2

F

vis

x2

Répéter l'étape 33. dans les joues 1 et 5 pour fixer la tringle droite sous la tablette 11.

⚠ Les vis sont à visser sans pré-perçage préalable.

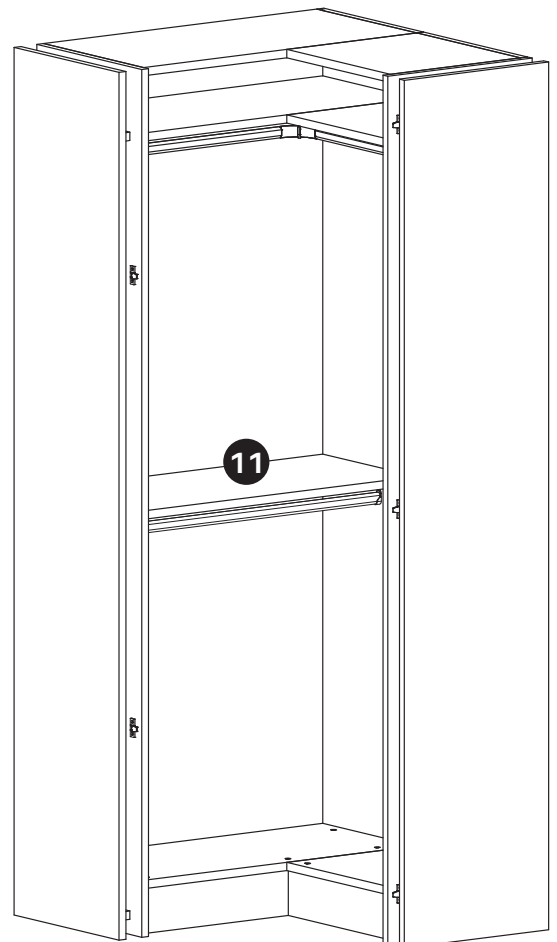
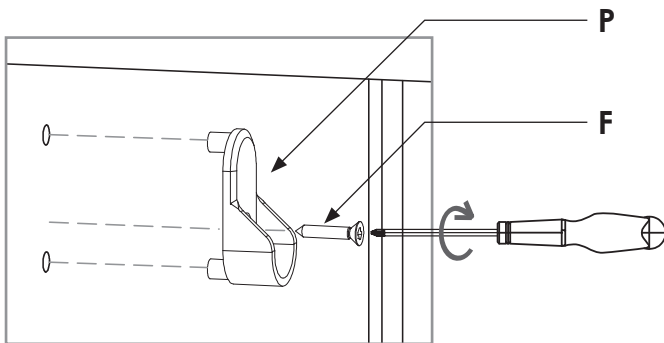

Si **MEUBLE D'ANGLE** utilisé seul : passer à l'étape **37a**.

Si **MEUBLE D'ANGLE** utilisé avec un Konsilio à droite et/ou à gauche : passer à l'étape **37b**.

37a.

OUTILS

tournevis



QUINCAILLERIE

Sachet n°834

x2

Q ferrure femelle

x10

F vis

x20

ÉTAPE 1

x2

2 et 16 : largeur 100 mm

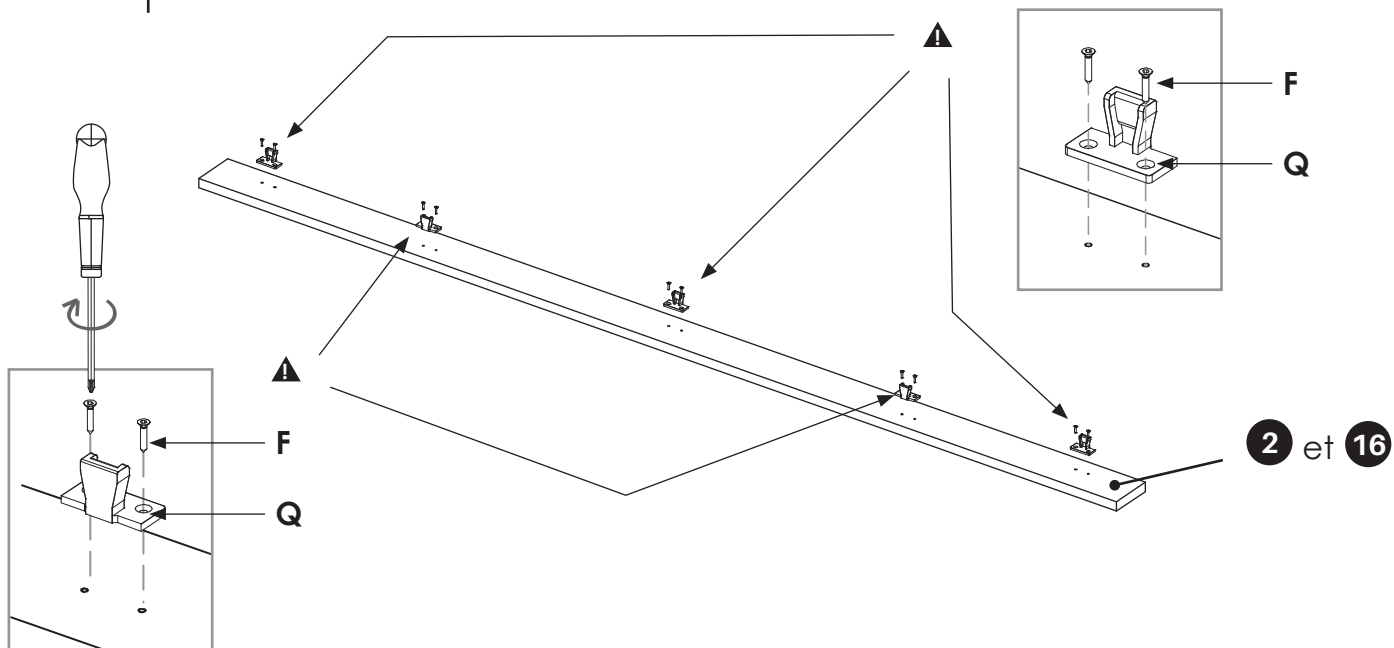

ÉTAPE 2 : Positionner les montants 2 et 16

VUE DE DESSUS

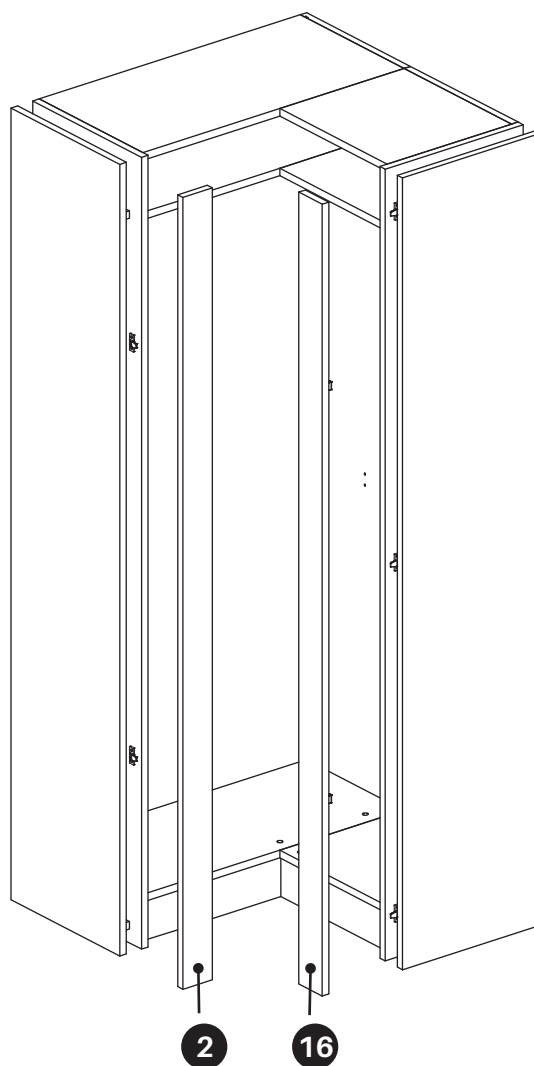
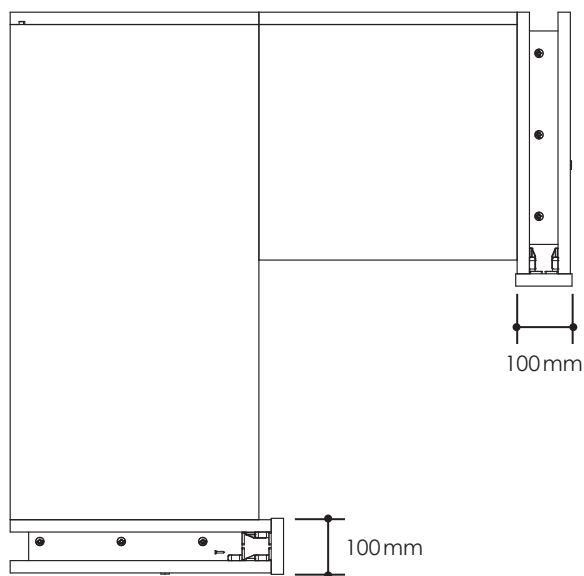

37b.

OUTILS

tournevis



QUINCAILLERIE

	Sachet n°834	x2
Q	ferrure femelle	x10
F	vis	x20

Monter l'espace d'angle en premier, à l'exception des montants larges.

ÉTAPE 1 : 21 et 22 : largeur 122 mm

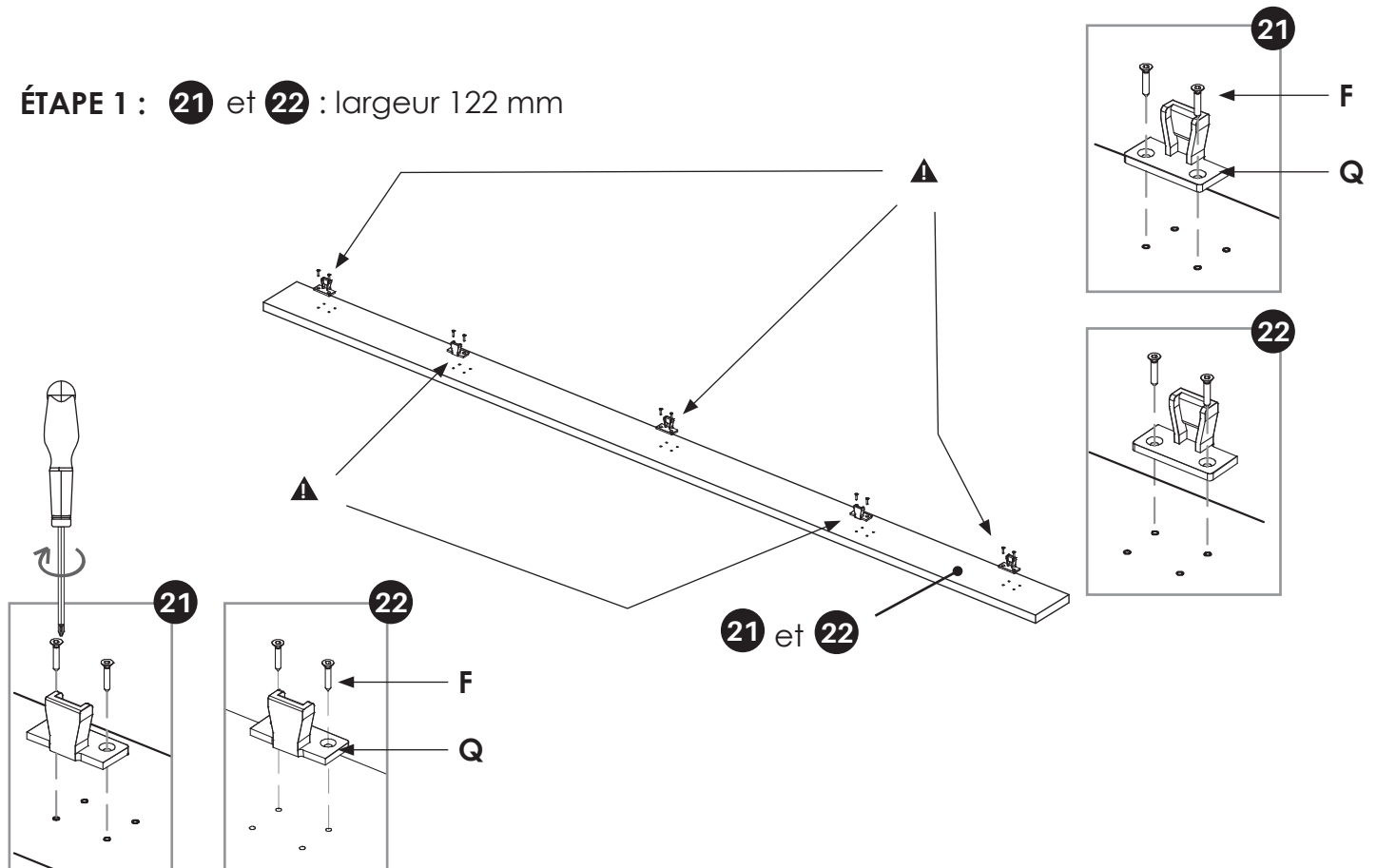

ÉTAPE 2 : Positionner les montants 21 et 22 afin que ce(s) dernier(s) recouvre(nt) la/les joue(s) externe(s) du/des Konsilio.

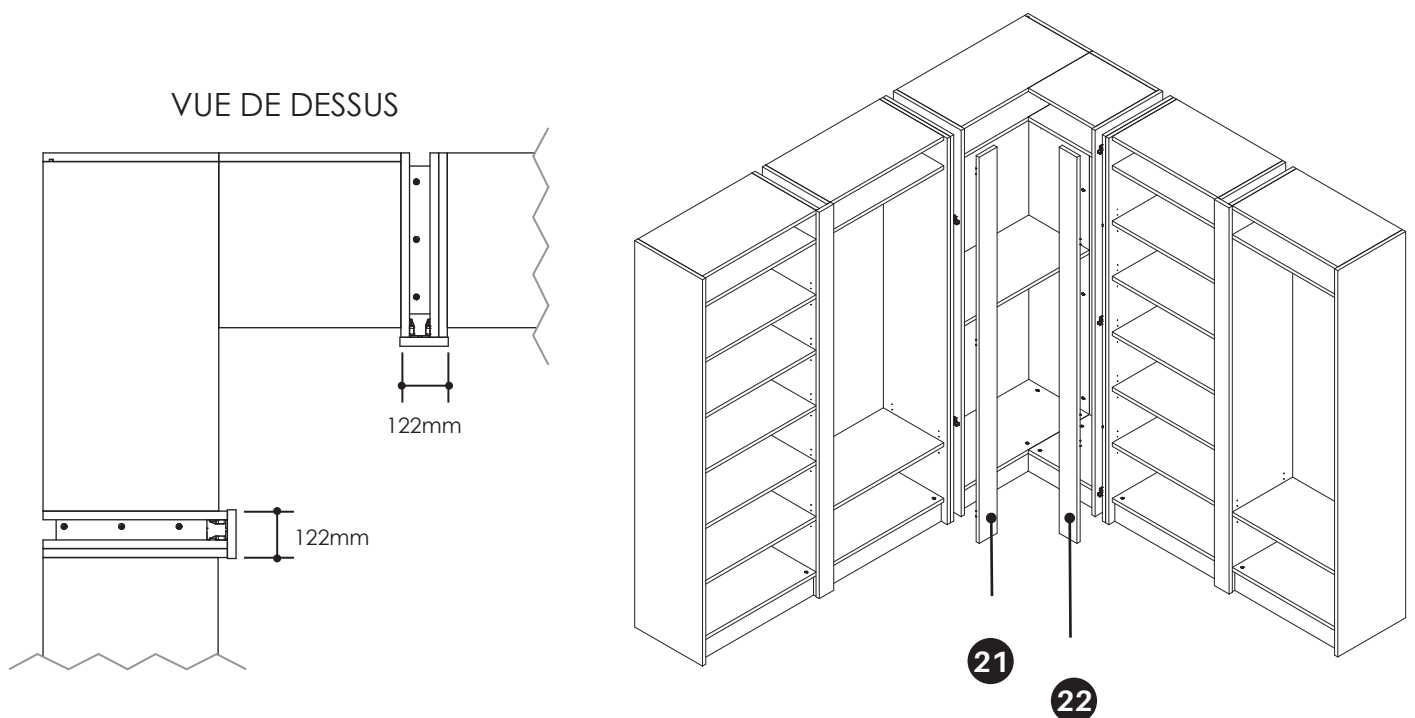

KAZED À VOTRE ÉCOUTE



05 49 25 40 29



SAS KAZED
45 allée des Grands Champs
CS90066
79260 La Crèche



www.kazed.fr
www.kazed.store

 **Kazed**

